

**Municipal Drain No. 39 - 2018  
Town of Minto  
County of Wellington**



**DIETRICH ENGINEERING LIMITED**  
CONSULTING ENGINEERS

*Reference No. 1617*

*June 20, 2018*

**Contents**

1.0	Introduction	1
2.0	History	1
3.0	On-Site Meeting	2
4.0	Information Meeting	3
5.0	Findings	4
6.0	Recommendations	5
7.0	Summary of Proposed Works	5
8.0	Working Area and Access	5
9.0	Watershed Characteristics	5
10.0	Soil Characteristics	6
11.0	Allowances	7
12.0	Estimated Construction Costs	8
13.0	Summary of Estimated Construction Costs	12
14.0	Summary of Estimated Costs	12
15.0	Assessment	13
16.0	Maintenance	13
	Schedule of Assessment for Construction – Main Drain	14
	Schedule of Assessment for Construction – Branch ‘C’	15
	Schedule of Net Assessment for Construction	16
	Schedule of Assessment for Maintenance – Main Drain	17
	Schedule of Assessment for Maintenance – Branch ‘C’	18

Specifications for the Construction of Municipal Drainage Works

DIVISION A-General Conditions

DIVISION B-Specification for Open Drains

DIVISION C-Specification for Tile Drains

DIVISION E-Specification for Drainage Crossings by the Boring Method

DIVISION H-Special Provisions

Kitchener, Ontario

June 20, 2018

**Municipal Drain No. 39 - 2018**  
**Town of Minto**  
**County of Wellington**

**To the Mayor and Council  
of the Town of Minto**

**Members of Council:**

**1.0 Introduction**

We are pleased to present our report on “Municipal Drain No. 39 - 2018”, serving parts of Lots 5 to 7, Concessions 6 and 7, in the Town of Minto, County of Wellington.

Authority to prepare this report was obtained by a resolution of the Town of Minto Council at its May 3, 2016 meeting to appoint Dietrich Engineering Limited to prepare an Engineer’s Report.

In accordance with your instructions pursuant to:

1. A request received by the Town of Minto Council under Section 78 of the Drainage Act, R.S.O. 1990, signed by Ronald and Debra Ross (Roll No. 4-151), Lot 5, Concession 6, and;
2. A petition received by the Town of Minto Council under Section 4(1)(c) of the Drainage Act, R.S.O. 1990, signed by Mike McIsaac, Town of Minto Road Foreman,

we have made an examination and survey of the affected areas and submit herewith our Report which includes Plan, Profiles, Details and Specifications for this work.

The attached Plan, Profiles, and Details, Drawings No. 1 and 2, Reference No. 1617, Specifications and the Instructions to Tenderers form part of this report. They show and describe in detail the location and extent of the work to be done and the lands which are affected

**2.0 History**

The upper end of Municipal Drain No. 39 was originally constructed under the authority of a report prepared by James A. Howes, O.L.S., dated February 4, 1957.

The report provided for the installation of approximately 3,125 lineal feet (952 metres) of 6 inch diameter (150 mm) to 10 inch (250 mm) diameter tile and the installation of four (4) catch basins. The outlet for the drain was into a woodlot on the west half of Lot 7, Concession 7.

From the outlet, the drain proceeds south-easterly through the east part of Lot 7 and the south-west corner of Lot 8, Concession 7, before it crosses through 6<sup>th</sup> Line road. From the south side of 6<sup>th</sup>

Line, the tile drain continues through the north-east part of Lot 6, Concession 6, crossing through 1<sup>st</sup> Road North and the north-west part of Lot 5, Concession 6, to the head of the drain on the south side of 6<sup>th</sup> Line.

For the lower end of Municipal Drain No. 39, an old award drain in part of Lot 9 and Lot 10, Concession 7, was replaced with a new municipal drain under the authority of a report prepared by J. R. Spriet, P.Eng., of Spriet Associates London Limited, dated October 28, 1991.

The report provided for the installation of approximately 569 metres of 350 mm diameter to 450 mm diameter field tile, one (1) 6 metre length of 600 mm diameter corrugated metal outlet pipe, the installation of one (1) catch basin, the installation of an 800 mm diameter corrugated metal pipe culvert, the construction of a low flow culvert under Road 10-11(Pike Lake Road), and the excavation of approximately 225 metres of the existing open ditch know as Municipal Drain No 3.

The drain commenced at an outlet into the open ditch of Municipal Drain No. 3 in the south-west part of Lot 10, Concession 7, and proceeded north-easterly through Lot 10, turning south at the Lot 9 property line before coming to the head of the drain at the property line between the east half and west half of Lot 9, Concession 7.

The lower end of Municipal Drain No. 39 was extended under the authority of a report prepared by J. R. Spriet, P.Eng., of Spriet Associates London Limited, dated February 28, 1997.

The report provided for the extension of the Main Drain, consisting of the installation of approximately 593 metres of 300 mm diameter to 450 mm diameter concrete and high density polyethylene pipe, and two (2) catch basins.

Branch 'A', consisting of the installation of approximately 617 metres of 200 mm diameter to 350 mm diameter concrete and plastic field tile and 19 metres of smooth wall steel casing under 6<sup>th</sup> Line, and two (2) catch basins.

Branch 'B', consisting of the installation of approximately 193 metres of 200 mm diameter plastic field tile.

The Main Drain extension was constructed from its outlet into the upper end of the 1991 tile drain between the east and west halves of Lot 9, Concession 7, in a south-easterly direction to the property line between Lot 8 and Lot 9, Concession 7, then north-easterly to the head of the drain on upstream side of a laneway in the middle of Lot 8, Concession 7.

Branch 'A' commenced at an outlet into the new extension of the Main Drain at the property line between Lot 8 and Lot 9, Concession 7, then proceeded south-easterly through the 6<sup>th</sup> Line road to the head of the drain at the property line between Lot 7 and Lot 8, Concession 6.

Branch 'B' commenced at an outlet into the new extension of the Main Drain, approximately 28 metres east of the east and west halves of Lot 9, Concession 7, to the property line between Lot 8 and Lot 9, Concession 7.

### **3.0 On-Site Meeting**

In accordance with Section 9(1) of the Drainage Act, R.S.O. 1990, an on-site meeting was held on November 4, 2016. The place of meeting was on the 6<sup>th</sup> Line road allowance, adjacent to the Lena Martin property, Part of Lot 6, Concession 7.

Persons in attendance were:

Greg Nancekivell, C.E.T.	Dietrich Engineering Limited
Michel Terzian	Dietrich Engineering Limited
Mike Mclsaac	Road Foreman, Town of Minto
Edgar Martin	Landowner ( <i>Pt. Lot 6, Con. 6</i> )
Ronald Ross	Landowner ( <i>Lot 5, Con. 6</i> )
Jessie Ross	Landowner ( <i>Pt. Lot 6, Con. 6</i> )
David Campbell	Landowner ( <i>Lot 8, Con. 7</i> )
Linda Sinclair	Landowner ( <i>Pt. Lot 7, Con. 7</i> )
Jim McLaughlin	Landowner ( <i>Pt. Lot 8, Con. 6</i> )

Comments, concerns and issues that were discussed at the On-Site Meeting include:

- The existing drains on the west part of Lot 7, Concession 7, are working fine with no issues.
- The main drain through Lot 8, Concession 7, works well, property owner has no concerns.
- Existing tile has some blowouts through the north part of Lot 6, Concession 6.
- Would like a new branch brought up to the road on the L. Martin property, part of Lot 7, Concession 7, because there is typically a wet spot north of the road, opposite an existing surface pipe through 6<sup>th</sup> Line, adjacent to the H. & B. Savage property (Roll No. 4-153-01), part of Lot 7, Concession 6.
- The woodlot on part of Lot 7 and part of Lot 8, Concession 7, is a low hole and wet all the time, water just stays in it.
- The watershed needs to be checked in a few spots.
- Landowners would like to see the drain replaced with bigger and deeper tile.
- Generally a sandy loam soil within the watershed.

#### 4.0 Information Meeting

An information meeting was held on March 9, 2018, at the Town of Minto Municipal Office. Persons in attendance were:

Greg Nancekivell, C.E.T.	Dietrich Engineering Ltd.
Michel Terzian	Dietrich Engineering Ltd.
Mike Mclsaac	Road Foreman, Town of Minto
Shane Ross	Representing Ronald & Debra Ross ( <i>Lot 5, Con. 6</i> )
Edgar Martin	Landowner ( <i>Pt. Lot 6, Con. 6</i> )
Terry Ross	Representing Jessie Ross ( <i>Pt. Lot 6, Con. 6</i> )
Linda Sinclair	Landowner ( <i>Pt. Lot 7, Con. 7</i> )
Mark & Maynard Martin	Landowners ( <i>Pt. Lot 5, Con. 7</i> )

Comments, concerns and issues that were discussed at the Information Meeting include:

- Attendees were presented with the proposed design for the Main Drain, which consisted of the installation of approximately 1,078 metres of 300 mm to 500 mm diameter concrete field tile, high density polyethylene pipe and smooth wall steel casing, the excavation of approximately 48 metres of existing open ditch, and the installation of eight (8) concrete catch basins and one (1) concrete junction box.

- Branch 'C' consisted of the installation of approximately 58 metres of 200 mm diameter concrete field tile, and the one (1) concrete catch basin.
- The new proposed drain is designed for a 1.5" Drainage Coefficient (38.1 mm of rainfall per 24 hours) which attendees thought should be the minimum design standard.
- There were concerns about the ability of the woodlot on the west part of Lot 7, Concession 7, to accommodate the water from the new and larger drainage system without causing flooding within the woodlot and on downstream lands.
- The owners of Lot 5, Concession 7, intend to systematically tile their property and would like to tile some land from outside the watershed on the east side of the laneway, into the watershed for the new drainage system, so make sure the tile is sized for the extra water. A map detailing the configuration of the proposed tiling system was provided to Dietrich Engineering staff at the meeting.

## 5.0 Findings

We have made an examination of the drainage area and have found the following:

1. Municipal Drain No. 39 constructed under the authority of a report prepared by James A. Howes, O.L.S., dated February 4, 1957, is in a poor state of repair and is neither of sufficient capacity nor depth to drain the surrounding and upstream lands within the watershed at today's standards of drainage.
2. M. & M. Martin, landowners of part of Lot 5, Concession 7, would like to systematically tile approximately 2 hectares of land (5 acres) from outside the watershed east of their laneway, into the proposed drainage system.
3. Water doesn't drain away from an area on the L. Martin property (Roll No. 4-168) on the east part of Lot 7, Concession 7, on the north side of 6<sup>th</sup> Line, opposite an existing surface pipe through 6<sup>th</sup> Line, and typically remains wet.
4. Part of the woodlot on west part of Lot 7, Concession 7, is an Evaluated but non-Provincially Significant Wetland according to the Ministry of Natural Resources and Forestry website.
5. Approximately 1.2 hectares (3 acres) of the R. & D. Ross property (Roll No. 4-151), Lot 5, Concession 6, is tiled out of the watershed for the proposed drainage system.
6. Landowners of Lots 8 to 10, Concession 7, and Lots 8 and 9, Concession 6, were invited to the on-site meeting dated November 4, 2016, to discuss any drainage issues they may have and wish to address through a new drainage report. At the time, there was no interest from those property owners to have improvements made to the existing drainage systems through their lands.
7. Landowners on Lot 8 and part of Lot 9, Concessions 6 and 7, were mailed a letter dated April 6, 2018, advising them that an information meeting with the affected landowners for the upper end of Municipal Drain No. 39, had taken place and that the downstream landowners who received a copy of the letter, would not be assessed for the proposed drainage works. Landowners were instructed to contact the office of the engineer if they had any questions or concerns regarding the proposed work.
8. The drainage coefficient design standard used for the Municipal Drain No. 39 extension in 1997 is 13 mm (0.5") of rainfall per 24 hours.

## 6.0 Recommendations

It is our recommendation that:

1. A new tile drainage system, **Main Drain**, be constructed from its outlet on the L. Sinclair property (Roll No. 4-167), part of Lot 7, Concession 7, upstream approximately 1,078 metres to the north road limit of 6<sup>th</sup> Line, in the Town of Minto, Wellington County.
2. A new tile drainage system, **Branch 'C'**, be constructed from its outlet into the Main Drain on the L. Martin property (Roll No. 4-168), part of Lot 7, Concession 7, upstream approximately 58 metres to the north road limit of 6<sup>th</sup> Line, in the Town of Minto, County of Wellington.
3. The existing tile drainage system constructed under the authority of the report prepared by James A. Howes, O.L.S., dated February 4, 1957, shall be abandoned and destroyed.
4. This new drainage system shall be known as "**Municipal Drain No. 39 - 2018**".
5. The drainage coefficient design standard used for this drain is 38.1 mm (1.5") of rainfall per 24 hours.

## 7.0 Summary of Proposed Works

The proposed work on the Main Drain consists of approximately 48 metres of existing open ditch excavation; 1,038 metres of 300 mm to 450 mm diameter concrete field tile and high density polyethylene pipe; the installation of eight (8) concrete catch basins and one (1) concrete junction box; and the installation of 40 metres of 400 mm to 500 mm O.D. smooth wall steel casing to be installed by the jack & bore method.

The proposed work on Branch 'C' consists of approximately 58 metres of 200 mm diameter concrete field tile; and the installation of one (1) concrete catch basin.

## 8.0 Working Area and Access

The working area for construction purposes shall be a width of twenty-five (25) metres for the Main Drain and Branch 'C', except for in the woodlot on the L. Sinclair property (Roll no. 4-167), part of Lot 7, Concession 7, from Main Drain Sta. 0+000 to Sta. 0+048, where the working area shall be a width of twenty (20) metres.

The working area for maintenance purposed shall be a width of ten (10) metres centered on the proposed tile drain.

Access to the working corridor on the L. Sinclair property, part of Lot 7, Concession 7, shall be along a 5 metre wide access route as shown on the attached Plan (Drawing No. 1 of 2).

Access to the working corridor for Main Drain Sta. 0+079 to Sta. 1+078 and Branch 'C' shall be from where the proposed drain crosses 6<sup>th</sup> Line and 1<sup>st</sup> Road North.

## 9.0 Watershed Characteristics

The Drainage Area comprises approximately 41.5 hectares (102.5 acres). Land use within the watershed is primarily agricultural.

The watersheds were established using historic drainage reports, field investigations, Global Positioning System (G.P.S.) surveys and Southwestern Ontario Orthophotography Project (SWOOP) data.

## **10.0 Soil Characteristics**

The Ontario Ministry of Agriculture, Food and Rural Affairs Agricultural Information Atlas, available online, describes the soil types within the watershed mostly as Harriston Loam, with a small pocket of Listowel Loam and an area of Muck within the woodlot on Lot 7, Concession 7.

A soils investigation by Dietrich Engineering Ltd. staff on November 11, 2016, generally confirm the above noted characteristics. Six (6) test pits were dug to an average depth of 2 metres and no water was encountered at the time. The average topsoil depth that was observed during the investigation was approximately 400 mm.



## 11.0 Allowances

In accordance with Sections 29 and 30 of the Drainage Act, R.S.O. 1990, we determine the allowances payable to Owners entitled thereto as follows.

Lot or Part	Con.	Owner	Roll No.	Right-of-Way (Section 29)	Damages to Lands and Crops (Section 30)	Total Allowances
<b>MAIN DRAIN</b>						
5	6	R. & D. Ross	4-151	\$ 2,930	\$ 2,600	\$ 5,530
Pt. 6	6	E. & L. Martin	4-152	\$ 3,030	\$ 2,690	\$ 5,720
W Pt. 7	7	L. & S. Sinclair	4-167	\$ 1,430	\$ 1,310	\$ 2,740
W Pt. 7 & E Pt. 6	7	L. Martin	4-168	\$ 4,610	\$ 4,100	\$ 8,710
5	7	M., J., M. & F. Martin	4-171		\$ 500	\$ 500
<b>TOTAL ALLOWANCES, MAIN DRAIN</b>				<b>\$12,000</b>	<b>\$11,200</b>	<b>\$23,200</b>
<b>BRANCH 'C'</b>						
W Pt. 7 & E Pt. 6	7	L. Martin	4-168	\$ 650	\$ 580	\$ 1,230
<b>TOTAL ALLOWANCES, BRANCH 'C'</b>				<b>\$ 650</b>	<b>\$ 580</b>	<b>\$ 1,230</b>
<b>TOTAL ALLOWANCES, MUNICIPAL DRAIN NO. 39 - 2018</b>				<b>\$12,650</b>	<b>\$11,780</b>	<b>\$24,430</b>

Total Allowances, under Sections 29 and 30 of the Drainage Act, R.S.O. 1990;

**Municipal Drain No. 39 - 2018**

**\$24,430**

### Section 29 (Right-of-Way)

The land value used for calculating allowances for Right-of-Way is \$45,000/ha (\$18,212/acre) for agricultural lands and \$15,000/ha (\$6,071/acre) for woodlots.

Right-of-Way allowances have been calculated based on 25% of the estimated land value for a 10 metre Right-of-Way. Where lands were taken out of production for the construction of the Municipal Drain, Right-of-Way allowances have been calculated based on 100% of the estimated land value for the full area of land that was taken out of production.

Allowances for Right-of-Way were not provided in the report prepared by James A. Howes, O.L.S. dated February 4, 1957.

### Section 30 (Damages)

Damages have been calculated based on \$4,000/ha (\$1,619/acre) for agricultural lands and \$2,000/ha (\$809/acre) for woodlots.

Allowances for accessing the working corridor along the route of the drain were awarded as Damages under Section 30 of the Drainage Act and were based on the length of the access route from the adjacent road and a 5 metre access route width using a value of \$4,000/ha (\$1,619/acre).

## 12.0 Estimated Construction Costs

We have made an estimate of the cost of the proposed work which is outlined in detail as follows:

### Labour, Equipment and Materials

#### A) MAIN DRAIN

	<u>Description</u>	<u>Quantity</u>	<u>\$/Unit</u>	<u>Total</u>
1)	Open Ditch Excavation (Sta. 0+000 to Sta. 0+048)	100 m <sup>3</sup>	\$ 4.00	\$ 400.00
2)	Levelling of Excavated material (Sta. 0+000 to Sta. 0+048)	48 m	\$ 3.00	\$ 144.00
3)	Stripping and stock piling of topsoil, 10m width (Sta. 0+000 to Sta. 0+489, Sta. 0+509 to Sta. 0+778 & Sta. 0+798 to Sta. 1+058)	1,018 m	\$ 7.00	\$ 7,126.00
4)	Levelling of stripped topsoil with trim dozer (Sta. 0+000 to Sta. 0+489, Sta. 0+509 to Sta. 0+778 & Sta. 0+798 to Sta. 1+058)	1,018 m	\$ 3.00	\$ 3,054.00
5)	Supply 450mm diameter, H.D.P.E. solid outlet pipe complete with rodent grate (320 kPa, CSA B182.8, bell and spigot joining system)	6 m	\$ 65.00	\$ 390.00
	Installation of 450mm diameter H.D.P.E. outlet pipe (Sta. 0+000 to Sta. 0+006)	l.s.		\$ 500.00
6)	Quarry stone rip-rap protection and geotextile filter material (Mirafi 180N or equivalent, approximately 40m <sup>2</sup> )	l.s.		\$ 1,500.00
7)	Supply 450mm diameter H.D.P.E. solid pipe (320 kPa, CSA B182.6, bell and spigot joining system)	150 m	\$ 65.00	\$ 9,750.00
	Installation of 450mm H.D.P.E. diameter pipe by means of excavator on crushed stone bedding (Sta. 0+006 to Sta. 0+079 & Sta. 0+412 to Sta. 0+489)	150 m	\$ 50.00	\$ 7,500.00
8)	Supply 450mm diameter concrete field tile (2000D)	333 m	\$ 29.00	\$ 9,657.00
	Installation of 450mm diameter concrete field tile by means of a wheel trencher (Sta. 0+079 to Sta.0+412)	333 m	\$ 24.00	\$ 7,992.00

9)	Supply 400mm diameter concrete field tile (2000D)	269 m	\$ 24.00	\$ 6,456.00
	Installation of 400mm diameter concrete field tile by means of a wheel trencher (Sta. 0+509 to Sta.0+778)	269 m	\$ 22.00	\$ 5,918.00
10)	Supply 300mm diameter concrete field tile (2000D)	260 m	\$ 16.00	\$ 4,160.00
	Installation of 300mm diameter concrete field tile by means of a wheel trencher (Sta. 0+798 to Sta.1+058)	260 m	\$ 20.00	\$ 5,200.00
11)	Supply 200mm diameter H.D.P.E. solid pipe (320 kPa, CSA B182.8, bell and spigot joining system)	9 m	\$ 15.00	\$ 135.00
	Installation of 200mm diameter H.D.P.E. pipe by means of excavator on crushed stone bedding (Offset D.I.C.B. lead at Sta. 0+448)	9 m	\$ 45.00	\$ 405.00
12)	Supply & install 900mm x 1200mm concrete ditch inlet catch basin including the removal of existing hickenbottom (Sta. 0+079)	1 ea.	\$ 3,000.00	\$ 3,000.00
13)	Supply & install 900mm x 1200mm junction box (Sta. 0+272)	1 ea.	\$ 2,000.00	\$ 2,000.00
14)	Supply & install 450mm x 200mm diameter H.D.P.E. solid tee (320 kPa, CSA B182.8, bell and spigot joining system) (Sta. 0+448)	1 ea.	\$ 500.00	\$ 500.00
15)	Supply & install 450mm diameter H.D.P.E. solid 45 deg. elbows (320 kPa, CSA B182.8, bell and spigot joining system, Sta. 0+483, Sta.0+489 & Sta. 0+509)	3 ea.	\$ 500.00	\$ 1,500.00
16)	Tile Connections	l.s.		\$ 1,023.00
	<b>Sub-Total</b>			<b>\$ 78,310.00</b>

17) Work to be done on the 6th Line  
Road Allowance (Sta. 0+489 to Sta. 0+509)

---

a) Supply 500 mm O.D. smooth wall steel casing 9.5mm (0.37") wall thickness	20 m	\$ 220.00	\$ 4,400.00
Installation of 500mm O.D. smooth wall steel casing by jack & bore method (Sta. 0+489 to Sta.0+509)	20 m	\$ 600.00	\$ 12,000.00
b) Supply & install 900mm x 1200mm concrete ditch inlet catch basin including the removal and offsite disposal of existing catch basin at Sta. 0+509 (Sta. 0+489 & Sta. 0+509)	2 ea.	\$ 3,000.00	\$ 6,000.00
c) Supply & install 600mm x 600mm concrete ditch inlet offset catch basin 9 metres south of Sta. 0+448 including connection to the Main Drain with 250 mm diameter H.D.P.E. pipe (320 kPa)	1 ea.	\$ 2,500.00	<u>\$ 2,500.00</u>
<b>Sub-Total</b>			<b><u>\$ 24,900.00</u></b>

18) Work to be done on the 1st Road North  
Road Allowance (Sta. 0+778 to Sta. 0+798)

---

a) Supply 375mm diameter H.D.P.E. solid pipe (320 kPa, CSA B182.8, bell and spigot joining system)	20 m	\$ 49.00	\$ 980.00
Installation of 375mm diameter H.D.P.E. by Excavator including granular base and backfill including the removal and offsite disposal of existing fill (open cut method) (Sta. 0+778 to Sta. 0+798)	l.s.		\$ 5,000.00
b) Supply & install 600mm x 600mm concrete ditch inlet catch basin including the removal and offsite disposal of existing catch basin at Sta. 0+798 (Sta. 0+798)	1 ea.	\$ 2,000.00	\$ 2,000.00
c) Supply & install 900mm x 1200mm concrete ditch inlet catch basin (Sta. 0+778)	1 ea.	\$ 3,000.00	\$ 3,000.00
d) Supply 450mm diameter H.D.P.E. solid pipe (320 kPa, CSA B182.8, bell and spigot joining system)	14 m	\$ 65.00	\$ 910.00
Installation of Road Culvert including the removal and offsite disposal of the existing 450mm diameter C.M.P. (Surface Culvert) (Sta. 0+781 to Sta. 0+795)	l.s.		<u>\$ 1,000.00</u>
<b>Sub-Total</b>			<b><u>\$ 12,890.00</u></b>

19) Work to be done on the 6th Line  
Road Allowance (Sta. 1+058 to Sta. 1+078)

---

a) Supply 400 mm O.D. smooth wall steel casing 9.5mm (0.37") wall thickness	20 m	\$ 200.00	\$ 4,000.00
Installation of 400mm O.D. smooth wall steel casing by jack & bore method (Sta. 1+056 to Sta.1+076)	20 m	\$ 500.00	\$ 10,000.00
b) Supply & install 600mm x 600mm concrete ditch inlet catch basin including the removal and offsite disposal of existing catch basin at Sta. 1+056 (Sta. 1+056 & Sta. 1+076)	2 ea.	\$ 2,000.00	\$ 4,000.00
<b>Sub-Total</b>			<b>\$ 18,000.00</b>

**TOTAL ESTIMATED CONSTRUCTION COSTS  
MAIN DRAIN**

**\$134,100.00**

---

**B) BRANCH 'C'**

	<u>Description</u>	<u>Quantity</u>	<u>\$/Unit</u>	<u>Total</u>
1)	Stripping and stock piling of topsoil, 10m width	58 m	\$ 7.00	\$ 406.00
2)	Levelling of stripped topsoil with trim dozer	58 m	\$ 3.00	\$ 174.00
3)	Supply 200mm diameter concrete field tile (2000D)	58 m	\$ 11.00	\$ 638.00
	Installation of 200mm diameter concrete field tile by means of a wheel trencher (Sta. 0+000 to Sta.0+058)	58 m	\$ 20.00	\$ 1,160.00
4)	Tile Connections	l.s.		\$ 222.00
	<b>Sub-Total</b>			<b>\$ 2,600.00</b>

5) Work to be done on the 6th Line  
Road Allowance (Sta. 0+058)

---

a) Supply & install 600mm x 600mm concrete ditch inlet catch basin (Sta. 0+058)	1 ea.	\$ 2,000.00	\$ 2,000.00
<b>Sub-Total</b>			<b>\$ 2,000.00</b>

**TOTAL ESTIMATED CONSTRUCTION COSTS  
BRANCH 'C'**

**\$ 4,600.00**

---

**TOTAL ESTIMATED CONSTRUCTION COSTS  
MUNICIPAL DRAIN NO. 39 - 2018**

**\$ 138,700.00**

---

### 13.0 SUMMARY OF ESTIMATED CONSTRUCTION COSTS

A) MAIN DRAIN	\$ 134,100.00
B) BRANCH 'C'	<u>\$ 4,600.00</u>

<b>TOTAL ESTIMATED CONSTRUCTION COSTS MUNICIPAL DRAIN NO. 39 - 2018</b>	<b><u><u>\$ 138,700.00</u></u></b>
-----------------------------------------------------------------------------	------------------------------------

Total Estimated Materials	\$ 63,838.00
Total Estimated Labour and Equipment	<u>\$ 74,862.00</u>

<b>TOTAL ESTIMATED CONSTRUCTION COSTS MUNICIPAL DRAIN NO. 39 - 2018</b>	<b><u><u>\$ 138,700.00</u></u></b>
-----------------------------------------------------------------------------	------------------------------------

### 14.0 SUMMARY OF ESTIMATED COSTS

Allowances under Sections 29 and 30 of the Drainage Act, R.S.O. 1990	\$ 24,430.00
----------------------------------------------------------------------	--------------

Total Estimated Construction Costs	\$ 138,700.00
------------------------------------	---------------

Meetings, survey, design, preparation of preliminary cost estimates and reports, preparation of final drainage report, consideration of report and court of revision	\$ 29,900.00
----------------------------------------------------------------------------------------------------------------------------------------------------------------------	--------------

Preparation of contract documents, contract administration, supervision and inspection of construction	\$ 12,500.00
--------------------------------------------------------------------------------------------------------	--------------

Contingencies, Interest, Soils Investigation and net H.S.T.	<u>\$ 8,370.00</u>
-------------------------------------------------------------	--------------------

<b>TOTAL ESTIMATED COSTS MUNICIPAL DRAIN NO. 39 - 2018</b>	<b><u><u>\$ 213,900.00</u></u></b>
----------------------------------------------------------------	------------------------------------

The estimated cost of the work in the Town of Minto is \$ 213,900.00.

## 15.0 Assessment

We assess the cost of this work against the lands and roads liable for assessment for benefit and outlet as shown on the annexed Schedule of Assessment. We have determined that there is no injuring liability assessment involved.

The existing Municipal Drain No. 39 constructed under the report of James A. Howes, O.L.S., dated February 4, 1957, shall be abandoned and cease to be a municipal drain after Municipal Drain No. 39 - 2018 is constructed.

Whether or not the Town of Minto elects to do the work on their property, Sta. 0+489 to Sta. 0+509, Sta. 0+778 to Sta. 0+798 and Sta. 1+058 to Sta. 1+078, they shall be assessed the actual increased costs to the drainage works due to the construction and operation of the roads as Special Assessments in addition to any benefit and outlet assessments. The Special Assessments shall be made up of the actual construction costs plus an allowance for administration costs.

## 16.0 Maintenance

After completion, this drain shall be maintained by the Town of Minto at the expense of all the lands and roads assessed in the attached Schedules of Assessments for Maintenance and in the same relative proportions until such time as the assessment is changed under the Drainage Act, with the exception of items included under report Section 12.0 Estimated Construction Costs for road works (Main Drain Item 17), 18) and 19), and Branch 'C' Item 5), which shall be maintained by the Town of Minto at the expense of the road authority having jurisdiction over the road.

Respectfully submitted,

**DIETRICH ENGINEERING LIMITED**



W. J. Dietrich, P.Eng.

WJD:mt







**SCHEDULE OF ASSESSMENT FOR CONSTRUCTION**  
**Municipal Drain No. 39 - 2018**  
**Town of Minto**



LOT OR PART	CON.	APPROX. HECTARES AFFECTED	OWNER	ROLL NO.	(SEC. 22) BENEFIT LIABILITY	(SEC. 23) OUTLET LIABILITY	(SEC. 26) SPECIAL ASSESSMENT	TOTAL ASSESSMENT	LESS 1/3 GOV'T GRANT	LESS ALLOWANCES	NET ASSESSMENT
<b><u>MAIN DRAIN</u></b>											
5	6	8.5	R. & D. Ross	(4-151)	\$15,800	\$13,144		\$28,944	\$9,648	\$5,530	\$13,766
Pt 6	6	10.2	E. & L. Martin	(4-152)	\$17,200	\$11,146		\$28,346	\$9,449	\$5,720	\$13,177
Pt. 6	6	3.5	J. Ross	(4-152-50)		\$5,282		\$5,282	\$1,761		\$3,521
7	6	1.5	H. & B. Savage	(4-153)		\$785		\$785	\$262		\$523
* Pt. 7	6	0.3	H. & B. Savage	(4-153-01)		\$219		\$219			\$219
* Pt. 7	6	0.4	H. Savage	(4-153-03)		\$287		\$287			\$287
* Pt. 5	7	0.2	S. Howe & P. Harris	(4-170)		\$633		\$633			\$633
5	7	2.1	M., J., M. & F. Martin	(4-171)	\$2,500	\$6,497		\$8,997	\$2,999	\$500	\$5,498
E. Pt 6	7	1.1	L. Martin	(4-169)		\$987		\$987	\$329		\$658
* Pt. 6	7	1.0	The Trustees of Old Order Mennonite Conference	(4-169-10)		\$911		\$911			\$911
W. Pt 7, E. Pt 6	7	8.9	L. Martin	(4-168)	\$24,500	\$4,379		\$28,879	\$9,626	\$8,710	\$10,543
W. Pt 7	7	0.8	L. & S. Sinclair	(4-167)	\$5,000	\$84		\$5,084	\$1,695	\$2,740	\$649
Total Assessment on Lands					<u>\$65,000</u>	<u>\$44,354</u>		<u>\$109,354</u>	<u>\$35,769</u>	<u>\$23,200</u>	<u>\$50,385</u>
1st Road North		1.4	Town of Minto		\$3,000	\$6,691	\$16,040	\$25,731			\$25,731
6th Line		1.6	Town of Minto		\$6,000	\$9,585	\$54,230	\$69,815			\$69,815
Total Assessment on Roads					<u>\$9,000</u>	<u>\$16,276</u>	<u>\$70,270</u>	<u>\$95,546</u>			<u>\$95,546</u>
<b>Total Assessment on Lands and Roads, Municipal Drain No. 39 - 2018 (Main Drain)</b>					<u><b>\$74,000</b></u>	<u><b>\$60,630</b></u>	<u><b>\$70,270</b></u>	<u><b>\$204,900</b></u>	<u><b>\$35,769</b></u>	<u><b>\$23,200</b></u>	<u><b>\$145,931</b></u>

- NOTES:
- \* Denotes lands not eligible for ADIP grants
  - The NET ASSESSMENT is the total estimated assessment less a one-third (1/3) Provincial grant, and allowances, if applicable.
  - The NET ASSESSMENT is for information purposes only

**SCHEDULE OF ASSESSMENT FOR CONSTRUCTION**  
**Municipal Drain No. 39 - 2018**  
**Town of Minto**



LOT OR PART	CON.	APPROX. HECTARES AFFECTED	OWNER	ROLL NO.	(SEC. 22) BENEFIT LIABILITY	(SEC. 23) OUTLET LIABILITY	TOTAL ASSESSMENT	LESS 1/3 GOV'T GRANT	LESS ALLOWANCES	NET ASSESSMENT
<b><u>BRANCH 'C'</u></b>										
7	6	1.5	H. & B. Savage	(4-153)		\$1,383	\$1,383	\$461		\$922
* Pt. 7	6	0.3	H. & B. Savage	(4-153-01)		\$329	\$329			\$329
* Pt. 7	6	0.4	H. Savage	(4-153-03)		\$423	\$423			\$423
W. Pt 7, E. Pt 6	7	0.4	L. Martin	(4-168)	\$3,000	\$168	\$3,168	\$1,056	\$1,230	\$882
Total Assessment on Lands					\$3,000	\$2,303	\$5,303	\$1,517	\$1,230	\$2,556
6th Line		0.3	Town of Minto		\$2,500	\$1,197	\$3,697			\$3,697
Total Assessment on Roads					\$2,500	\$1,197	\$3,697			\$3,697
<b>Total Assessment on Lands and Roads, Municipal Drain No. 39 - 2018 (Branch 'C')</b>					<b>\$5,500</b>	<b>\$3,500</b>	<b>\$9,000</b>	<b>\$1,517</b>	<b>\$1,230</b>	<b>\$6,253</b>

- NOTES:
- \* Denotes lands not eligible for ADIP grants
  - The NET ASSESSMENT is the total estimated assessment less a one-third (1/3) Provincial grant, and allowances, if applicable.
  - The NET ASSESSMENT is provided for information purposes only

**SCHEDULE OF NET ASSESSMENT FOR CONSTRUCTION**  
**Municipal Drain No. 39 - 2018**  
**Town of Minto**



LOT OR PART	CON.	OWNER	ROLL NO.	MAIN DRAIN	BRANCH 'C'	TOTAL ASSESSMENT	LESS 1/3		NET ASSESSMENT
							GOV'T GRANT	LESS ALLOWANCES	
5	6	R. & D. Ross	(4-151)	\$28,944		\$28,944	\$9,648	\$5,530	\$13,766
Pt 6	6	E. & L. Martin	(4-152)	\$28,346		\$28,346	\$9,449	\$5,720	\$13,177
Pt. 6	6	J. Ross	(4-152-50)	\$5,282		\$5,282	\$1,761		\$3,521
7	6	H. & B. Savage	(4-153)	\$785	\$1,383	\$2,168	\$723		\$1,445
* Pt. 7	6	H. & B. Savage	(4-153-01)	\$219	\$329	\$548			\$548
* Pt. 7	6	H. Savage	(4-153-03)	\$287	\$423	\$710			\$710
* Pt. 5	7	S. Howe & P. Harris	(4-170)	\$633		\$633			\$633
5	7	M., J., M. & F. Martin	(4-171)	\$8,997		\$8,997	\$2,999	\$500	\$5,498
E. Pt 6	7	L. Martin	(4-169)	\$987		\$987	\$329		\$658
* Pt. 6	7	The Trustees of Old Order Mennonite Conference	(4-169-10)	\$911		\$911			\$911
W. Pt 7, E. Pt 6	7	L. Martin	(4-168)	\$28,879	\$3,168	\$32,047	\$10,682	\$9,940	\$11,425
W. Pt 7	7	L. & S. Sinclair	(4-167)	\$5,084		\$5,084	\$1,695	\$2,740	\$649
Total Assessment on Lands				<u>\$109,354</u>	<u>\$5,303</u>	<u>\$114,657</u>	<u>\$37,286</u>	<u>\$24,430</u>	<u>\$52,941</u>
1st Road North      Town of Minto				\$25,731		\$25,731			\$25,731
6th Line              Town of Minto				<u>\$69,815</u>	<u>\$3,697</u>	<u>\$73,512</u>			<u>\$73,512</u>
Total Assessment on Roads				<u>\$95,546</u>	<u>\$3,697</u>	<u>\$99,243</u>			<u>\$99,243</u>
<b>Total Assessment on Lands and Roads, Municipal Drain No. 39 - 2018</b>				<u><b>\$204,900</b></u>	<u><b>\$9,000</b></u>	<u><b>\$213,900</b></u>	<u><b>\$37,286</b></u>	<u><b>\$24,430</b></u>	<u><b>\$152,184</b></u>

- NOTES:
- \*1. Denotes lands not eligible for ADIP grants
  2. The NET ASSESSMENT is the total estimated assessment less a one-third (1/3) Provincial grant, and allowances, if applicable.
  3. The NET ASSESSMENT is provided for information purposes only

**SCHEDULE OF ASSESSMENT FOR MAINTENANCE**  
**Municipal Drain No. 39 - 2018**  
**Town of Minto**

LOT OR PART	CON.	APPROX. HECTARES AFFECTED	OWNER	ROLL NO.	PORTION OF MAINTENANCE COST
<b><u>MAIN DRAIN</u></b>					
5	6	8.5	R. & D. Ross	(4-151)	15.7%
Pt 6	6	10.2	E. & L. Martin	(4-152)	20.2%
Pt. 6	6	3.5	J. Ross	(4-152-50)	7.0%
7	6	1.5	H. & B. Savage	(4-153)	3.0%
* Pt. 7	6	0.3	H. & B. Savage	(4-153-01)	0.8%
* Pt. 7	6	0.4	H. Savage	(4-153-03)	1.1%
* Pt. 5	7	0.2	S. Howe & P. Harris	(4-170)	0.6%
5	7	2.1	M., J., M. & F. Martin	(4-171)	6.2%
E. Pt 6	7	1.1	L. Martin	(4-169)	2.1%
* Pt. 6	7	1.0	The Trustees of Old Order Mennonite Conference	(4-169-10)	1.9%
W. Pt 7, E.	7	8.9	L. Martin	(4-168)	17.7%
W. Pt 7	7	0.8	L. & S. Sinclair	(4-167)	1.6%
Total Assessment on Lands					77.9%
1st Road North		1.4	Town of Minto		8.2%
6th Line		1.6	Town of Minto		13.9%
Total Assessment on Roads					22.1%
<b>Total Assessment for Maintenance, Municipal Drain No. 39 - 2018 (Main Drain)</b>					<b>100.0%</b>

NOTES: \*1. Denotes lands not eligible for ADIP grants

**SCHEDULE OF ASSESSMENT FOR MAINTENANCE**  
**Municipal Drain No. 39 - 2018**  
**Town of Minto**

LOT OR PART	CON.	APPROX. HECTARES AFFECTED	OWNER	ROLL NO.	PORTION OF MAINTENANCE COST
<b><u>BRANCH 'C'</u></b>					
7	6	1.5	H. & B. Savage	(4-153)	37.7%
* Pt. 7	6	0.3	H. & B. Savage	(4-153-01)	9.0%
* Pt. 7	6	0.4	H. Savage	(4-153-03)	11.5%
W. Pt 7, E. Pt 6	7	0.4	L. Martin	(4-168)	<u>9.2%</u>
Total Assessment on Lands					<u>67.4%</u>
6th Line		0.3	Town of Minto		<u>32.6%</u>
Total Assessment on Roads					<u>32.6%</u>
<b>Total Assessment for Maintenance, Municipal Drain No. 39 - 2018 (Branch 'C')</b>					<b><u><u>100.0%</u></u></b>

NOTES: \*1. Denotes lands not eligible for ADIP grants

# **SPECIFICATIONS FOR THE CONSTRUCTION OF MUNICIPAL DRAINAGE WORKS**

**DIVISION A – General Conditions**

**DIVISION B – Specification for Open Drains**

**DIVISION C – Specification for Tile Drains**

**DIVISION E – Specification for Drainage  
Crossings by the Boring Method**

**DIVISION H – Special Provisions**

# DIVISION A

## GENERAL CONDITIONS

---

<u>A</u>	<u>CONTENT</u>	<u>PAGE</u>
A.1	SCOPE	1
A.2	TENDERS	1
A.3	EXAMINATIONS OF SITE, DRAWINGS AND SPECIFICATIONS	1
A.4	PAYMENT	2
A.5	CONTRACTOR'S LIABILITY INSURANCE	2
A.6	LOSSES DUE TO ACTS OF NATURE, ETC.	2
A.7	COMMENCEMENT AND COMPLETION OF WORK	3
A.8	WORKING AREA AND ACCESS	3
A.9	SUB-CONTRACTORS	3
A.10	PERMITS, NOTICES, LAWS AND RULES	3
A.11	RAILWAYS, HIGHWAYS AND UTILITIES	4
A.12	ERRORS AND UNUSUAL CONDITIONS	4
A.13	ALTERATIONS AND ADDITIONS	4
A.14	SUPERVISION	4
A.15	FIELD MEETINGS	4
A.16	PERIODIC AND FINAL INSPECTIONS	5
A.17	ACCEPTANCE BY THE MUNICIPALITY	5
A.18	WARRANTY	5
A.19	TERMINATION OF CONTRACT BY THE MUNICIPALITY	5
A.20	TESTS	6
A.21	POLLUTION	6
A.22	SPECIES AT RISK	6
A.23	ROAD CROSSINGS	6
A.24	LANEWAYS	7
A.25	FENCES	8
A.26	LIVESTOCK	8
A.27	STANDING CROPS	9
A.28	SURPLUS GRAVEL	9
A.29	IRON BARS	9
A.30	RIP-RAP	9
A.31	CLEARING, GRUBBING AND BRUSHING	9
A.32	RESTORATION OF LAWNS	9





# **DIVISION A**

## **GENERAL CONDITIONS**

---

### **A.1 SCOPE**

The work to be done under this contract consists of supplying all labour, equipment and materials to construct the drainage work as outlined in the Scope of Work, Drawings, General Conditions and other Specifications.

### **A.2 TENDERS**

Tenders are to be submitted on a lump sum basis for the complete works or a portion thereof, as instructed by the Municipality. The Scope of Work must be completed and submitted with the Form of Tender and Agreement. A certified cheque is required as Tender Security, payable to the Treasurer of the Municipality.

All certified cheques, except that of the bidder to whom the work is awarded will be returned within ten (10) days of the time the Contract is awarded. The certified cheque of the bidder to whom the work is awarded will be retained as Contract Security and returned when the Municipality receives a Completion Certificate for the work.

A certified cheque is not required if the Contractor provides an alternate form of Contract Security such as a Performance Bond for 100% of the amount of the Tender or other satisfactory security, if required/permitted by the Municipality. A Performance Bond may also be required to insure maintenance of the work for a period of one (1) year after the date of the Completion Certificate.

### **A.3 EXAMINATIONS OF SITE, DRAWINGS AND SPECIFICATIONS**

The Tenderer must examine the premises and site to compare them with the Drawings and Specifications in order to satisfy himself of the existing conditions and extent of the work to be done before submission of his Tender. No allowance shall subsequently be made on behalf of the Contractor by reason of any error on his part. Any estimates of quantities shown or indicated on the Drawings, or elsewhere are provided for the convenience of the Tenderer. Any use made of these quantities by the Tenderer in calculating his Tender shall be done at his own risk. The Tenderer for his own protection should check these quantities for accuracy.

The standard specifications (Divisions B through G) shall be considered complementary and where a project is controlled under one of the Divisions, the remaining Divisions will apply for miscellaneous works.

In case of any inconsistency or conflict between the Drawings and Specifications, the following order of precedence shall apply:

- Direction of the Engineer
- Special Provisions (Division H)
- Scope of Work
- Contract Drawings
- Standard Specifications (Divisions B through G)
- General Conditions (Division A)

#### A.4 PAYMENT

Progress payments equal to 87±% of the value of work completed and materials incorporated in the work will be made to the Contractor monthly. An additional ten per cent (10±%) will be paid 45 days after the final acceptance by the Engineer, and three per cent (3±%) of the Contract price may be reserved by the Municipality as a maintenance holdback for a one (1) year period from the date of the Completion Certificate. A greater percentage of the Contract price may be reserved by the Municipality for the same one (1) year period if in the opinion of the Engineer, particular conditions of the Contract requires such greater holdback.

After the completion of the work, any part of this reserve may be used to correct defects developed within that time from faulty workmanship and materials, provided that notice shall first be given to the Contractor and that he may promptly make good such defects.

#### A.5 CONTRACTOR'S LIABILITY INSURANCE

Prior to commencement of any work, the Contractor shall file with the Municipality evidence of compliance with all Municipality insurance requirements (Liability Insurance, WSIB, etc.) for no less than the minimum amounts as stated in the Purchasing Procedures of the Municipality. All insurance coverage shall remain in force for the entire contract period including the warranty period which expires one year after the date of the Completion Certificate.

The following are to be named as co-insured: Successful Contractor  
Sub-Contractor  
Municipality  
Dietrich Engineering Ltd.

#### A.6 LOSSES DUE TO ACTS OF NATURE, ETC.

All damage, loss, expense and delay incurred or experienced by the Contractor in the performance of the work, by reason of unanticipated difficulties, bad weather, strikes, acts of nature, or other mischances shall be borne by the Contractor and shall not be the subject of a claim for additional compensation.

#### A.7 COMMENCEMENT AND COMPLETION OF WORK

The work must commence as specified in the Form of Tender and Agreement. If conditions are unsuitable due to poor weather, the Contractor may be required, at the discretion of the Engineer to postpone or halt work until conditions become acceptable and shall not be subject of a claim for additional compensation.

The Contractor shall give the Engineer a minimum of 48 hours notice before commencement of work. The Contractor shall then arrange a meeting to be held on the site with Contractor, Engineer, and affected Landowners to review in detail the construction scheduling and other details of the work.

If the Contractor leaves the job site for a period of time after initiation of work, he shall give the Engineer and the Municipality a minimum of 24 hours notice prior to returning to the project. If any work is commenced without notice to the Engineer, the Contractor shall be fully responsible for all such work undertaken prior to such notification.

The work must proceed in such a manner as to ensure its completion at the earliest possible date and within the time limit set out in the Form of Tender and Agreement.

#### A.8 WORKING AREA AND ACCESS

Where any part of the drain is on a road allowance, the road allowance shall be the working area. For all other areas, the working area available to the Contractor to construct the drain is specified in the Special Provisions (Division H).

Should the specified widths become inadequate due to unusual conditions, the Contractor shall notify the Engineer immediately. Where the Contractor exceeds the specified working widths without authorization, he shall be held responsible for the costs of all additional damages.

If access off an adjacent road allowance is not possible, each Landowner on whose property the drainage works is to be constructed, shall designate access to and from the working area. The Contractor shall not enter any other lands without permission of the Landowner and he shall compensate the Landowner for damage caused by such entry.

#### A.9 SUB-CONTRACTORS

The Contractor shall not sublet the whole or part of this Contract without the approval of the Engineer.

#### A.10 PERMITS, NOTICES, LAWS AND RULES

The Contractor shall obtain and pay for all necessary permits or licenses required for the execution of the work (but this shall not include MTO encroachment permits, County Road permits permanent easement or rights of servitude). The Contractor shall give all necessary notices and pay for all fees required by law and comply with all laws, ordinances, rules and regulations relating to the work and to the preservation of the public's health and safety.

#### A.11 RAILWAYS, HIGHWAYS AND UTILITIES

A minimum of 72 hours' notice to the Railway or Highways, exclusive of Saturdays, Sundays, and Statutory Holidays, is required by the Contractor prior to any work activities on or affecting the applicable property. In the case of affected Utilities, a minimum of 48 hours' notice to the utility owner is required.

#### A.12 ERRORS AND UNUSUAL CONDITIONS

The Contractor shall notify the Engineer immediately of any error or unusual conditions which may be found. Any attempt by the Contractor to correct the error on his own shall be done at his own risk. Any additional cost incurred by the Contractor to remedy the wrong decision on his part shall be borne by the Contractor. The Engineer shall make the alterations necessary to correct errors or to adjust for unusual conditions during which time it will be the Contractor's responsibility to keep his men and equipment gainfully employed elsewhere on the project.

The Contract amount shall be adjusted in accordance with a fair evaluation of the work added or deleted.

#### A.13 ALTERATIONS AND ADDITIONS

The Engineer shall have the power to make alterations in the work shown or described in the Drawings and Specifications and the Contractor shall proceed to make such changes without causing delay. In every such case, the price agreed to be paid for the work under the Contract shall be increased or decreased as the case may require according to a fair and reasonable evaluation of the work added or deleted. The valuation shall be determined as a result of negotiations between the Contractor and the Engineer, but in all cases the Engineer shall maintain the final responsibility for the decision. Such alterations and variations shall in no way render the Contract void. No claims for a variation or alteration in the increased or decreased price shall be valid unless done in pursuance of an order from the Engineer and notice of such claims made in writing before commencement of such work. In no such case shall the Contractor commence work which he considers to be extra before receiving the Engineer's approval.

#### A.14 SUPERVISION

The Contractor shall give the work his constant supervision and shall keep a competent foreman in charge at the site.

#### A.15 FIELD MEETINGS

At the discretion of the Engineer, a field meeting with the Contractor or his representative, the Engineer and with those others that the Engineer deems to be affected, shall be held at the location and time specified by the Engineer.

#### A.16 PERIODIC AND FINAL INSPECTIONS

Periodic inspections by the Engineer will be made during the performance of the work. If ordered by the Engineer, the Contractor shall expose the drain as needed to facilitate inspection by the Engineer.

Final inspection by the Engineer will be made within twenty (20) days after he has received notice from the Contractor that the work is complete.

#### A.17 ACCEPTANCE BY THE MUNICIPALITY

Before any work shall be accepted by the Municipality, the Contractor shall correct all deficiencies identified by the Engineer and the Contractor shall leave the site neat and presentable.

#### A.18 WARRANTY

The Contractor shall repair and make good any damages or faults in the drain that may appear within one (1) year after its completion (as dated on the Completion Certificate) as the result of the imperfect or defective work done or materials furnished if certified by the Engineer as being due to one or both of these causes; but nothing herein contained shall be construed as in any way restricting or limiting the liability of the Contractor under the laws of the Country, Province or Locality in which the work is being done. Neither the Completion Certificate nor any payment there under, nor any provision in the Contract Documents shall relieve the Contractor from his responsibility.

#### A.19 TERMINATION OF CONTRACT BY THE MUNICIPALITY

If the Contractor should be adjudged bankrupt, or if he should make a general assignment for the benefit of his creditors, or if a receiver should be appointed on account of his insolvency, or if he should refuse or fail to supply enough properly skilled workmen or proper materials after having received seven (7) days notice in writing from the Engineer to supply additional workmen or materials to commence or complete the works, or if he should fail to make prompt payment to Sub-Contractors, or for material, or labour, or persistently disregards laws, ordinances, or the instruction of the Engineer, or otherwise be guilty of a substantial violation of the provisions of the Contract, then the Municipality, upon the certificate of the Engineer that sufficient cause exists to justify such action, may without prejudice to any other right or remedy, by giving the Contractor written notice, terminate the employment of the Contractor and take possession of the premises, and of all materials, tools and appliances thereon, and may finish the work by whatever method the Engineer may deem expedient but without delay or expense. In such a case, the Contractor shall not be entitled to receive any further payment until the work is finished. If the unpaid balance of the Contract price will exceed the expense of finishing the work including compensation to the Engineer for his additional services and including the other damages of every name and nature, such excess shall be paid by the Contractor. If such expense will exceed such unpaid balance, the Contractor shall pay the difference to the Municipality. The expense incurred by the Municipality, as herein provided, shall be certified by the Engineer.

If the Contract is terminated by the Municipality due to the Contractor's failure to properly commence the works, the Contractor shall forfeit the certified cheque bid deposit and furthermore shall pay to the Municipality an amount to cover the increased costs, if any, associated with a new Tender for the Contract being terminated.

If any unpaid balance and the certified cheque do not match the monies owed by the Contractor upon termination of the Contract, the Municipality may also charge such expense against any money which may thereafter be due to the Contractor from the Municipality.

#### A.20 TESTS

The cost for the testing of materials supplied to the job by the Contractor shall be borne by the Contractor. The Engineer reserves the right to subject any lengths of any tile or pipe to a competent testing laboratory to ensure the adequacy of the tile or pipe. If any tile supplied by the Contractor is determined to be inadequate to meet the applicable A.S.T.M. standards, the Contractor shall bear full responsibility to remove and/or replace all such inadequate tile in the Contract with tile capable of meeting the A.S.T.M. Standards.

#### A.21 POLLUTION

The Contractor shall keep their equipment in good repair. The Contractor shall refuel or repair equipment away from open water.

If polluted material from construction materials or equipment is caused to flow into the drain, the Contractor shall immediately notify the Ministry of the Environment, and proceed with the Ministry's protocols in place to address the situation.

#### A.22 SPECIES AT RISK

If a Contractor encounters a known Species at Risk as designated by the MNR or DFO, the Contractor shall notify the Engineer immediately and follow the Ministry's guidelines to deal with the species.

#### A.23 ROAD CROSSINGS

This specification applies to all road crossings (Municipality, County, Regional, or Highway) where no specific detail is provided on the drawings or in the standard specifications. This specification in no way limits the Road Authority's regulations governing the construction of drains on their Road Allowance.

##### A.23.1 Road Occupancy Permit

Where applicable, the Contractor must submit an application for a road occupancy permit to the Road Authority and allow a minimum of five (5) working days for its review and issuance.

#### A.23.2 Road Closure Request and Construction Notification

The Contractor shall submit written notification of construction and request for road closure (if applicable) to the Road Authority and the Engineer for review and approval a minimum of five (5) working days prior to proceeding with any work on the road allowance. The Contractor shall be responsible for notifying all applicable emergency services, schools, etc. of the road closure or construction taking place.

#### A.23.3 Traffic Control

The Contractor shall supply flagmen, and warning signs and ensure that detour routes are adequately signed in accordance with no less than the minimum standards as set out in the Ontario Traffic Manual's Book 7.

#### A.23.4 Weather

No construction shall take place during inclement weather or periods of poor visibility.

#### A.23.5 Equipment

No construction material and/or equipment is to be left within three (3) metres of the travelled portion of the road overnight or during periods of inclement weather.

If not stated on the drawings, the road crossing shall be constructed by open cut method. Backfill from the top of the cover material over the subsurface pipe or culvert to the under side of the road base shall be Granular "B". The backfill shall be placed in lifts not exceeding 300mm in thickness and each lift shall be thoroughly compacted to 98% Standard Proctor. Granular "B" road base for County Roads and Highways shall be placed to a 450mm thickness and Granular "A" shall be placed to a thickness of 200mm. Granular road base materials shall be thoroughly compacted to 100% Standard Proctor.

Where the road surface is paved, the Contractor shall be responsible for placing HL-8 Hot Mix Asphalt patch at a thickness of 50mm or of the same thickness as the existing pavement structure. The asphalt patch shall be flush with the existing roadway on each side and without overlap.

Excavated material from the trench beyond 1.25 metres from the travelled portion or beyond the outside edge of the gravel shoulder may be used as backfill in the trench in the case of covered drains. The material shall be compacted in lifts not exceeding 300mm.

### A.24 LANEWAYS

All pipes crossing laneways shall be backfilled with material that is clean, free of foreign material or frozen particles and readily tamped or compacted in place unless otherwise specified. Laneway culverts on open ditch projects shall be backfilled with material that is not easily erodible. All backfill material shall be thoroughly compacted as directed by the Engineer.

Culverts shall be bedded with a minimum of 300mm of granular material. Granular material shall be placed simultaneously on each side of the culvert in lifts not exceeding 150mm in thickness and compacted to 95% Standard Proctor Density. Culverts shall be installed a minimum of 10% of the culvert diameter below design grade with a minimum of 450mm of cover over the pipe unless otherwise noted on the Drawings.

The backfill over culverts and subsurface pipes at all existing laneways that have granular surfaces on open ditch and closed drainage projects shall be surfaced with a minimum of 300mm of Granular "B" material and 150mm of Granular "A" material. All backfill shall be thoroughly compacted as directed by the Engineer. All granular material shall be placed to the full width of the travelled portion.

Any settling of backfilled material shall be repaired by or at the expense of the Contractor during the warranty period of the project and as soon as required.

#### A.25 FENCES

No earth is to be placed against fences and all fences removed by the Contractor shall be replaced by him in as good a condition as found. Where practical the Contractor shall take down existing fences in good condition at the nearest anchor post and roll it back rather than cutting the fence and attempting to patch it. The replacement of the fences shall be done to the satisfaction of the Engineer. Any fences found in such poor condition where the fence is not salvageable, shall be noted and verified with the Engineer prior to commencement of work.

Fences damaged beyond repair by the Contractor's negligence shall be replaced with new materials, similar to those materials of the existing fence, at the Contractor's expense. The replacement of the fences shall be done to the satisfaction of the Landowner and the Engineer.

Any fences paralleling an open ditch that are not line fences that hinder the proper working of the excavating machinery, shall be removed and rebuilt by the Landowner at his own expense.

The Contractor shall not leave fences open when he is not at work in the immediate vicinity.

#### A.26 LIVESTOCK

The Contractor shall provide each landowner with 48 hours notice prior to removing any fences along fields which could possibly contain livestock. Thereafter, the Landowner shall be responsible to keep all livestock clear of the construction areas until further notified. The Contractor shall be held responsible for loss or injury to livestock or damage caused by livestock where the Contractor failed to notify the Landowner, or through negligence or carelessness on the part of the Contractor.



#### A.27 STANDING CROPS

The Contractor shall be responsible for damages to standing crops which are ready to be harvested or salvaged along the course of the drain and access routes if the Contractor has failed to notify the Landowners 48 hours prior to commencement of the work on that portion of the drain.

#### A.28 SURPLUS GRAVEL

If as a result of any work, gravel or crushed stone is required and not all the gravel or crushed stone is used, the Contractor shall haul away such surplus material.

#### A.29 IRON BARS

The Contractor is responsible for the cost of an Ontario Land Surveyor to replace any iron bars that are altered or destroyed during the course of the construction.

#### A.30 RIP-RAP

Rip-rap shall be quarry stone rip-rap material and shall be the sizes specified in the Special Provisions. Broken concrete shall not be used as rip-rap unless otherwise specified.

#### A.31 CLEARING, GRUBBING AND BRUSHING

This specification applies to all brushing where no specific detail is provided on the drawings or in the Special Provisions.

The Contractor shall clear, brush and stump trees from within the working area that interfere with the installation of the drainage system.

All trees, limbs and brush less than 150mm in diameter shall be mulched. Trees greater than 150mm in diameter shall be cut and neatly stacked in piles designated by the Landowners.

#### A.32 RESTORATION OF LAWNS

This specification applies to all lawn restoration where no specific detail is provided on the drawings or in the Special Provisions and no allowance for damages has been provided under Section 30 of the Drainage Act RSO 1990 to the affected property.

The Contractor shall supply "high quality grass seed" and the seed shall be broadcast by means of an approved mechanical spreader. All areas on which seed is to be placed shall be loose at the time of broadcast to a depth of 25mm. Seed and fertilizer shall be spread in accordance with the supplier's recommendations unless otherwise directed by the Engineer. Thereafter it will be the responsibility of the Landowner to maintain the area in a manner so as to promote growth.



# DIVISION B

## SPECIFICATIONS FOR OPEN DRAINS

---

<u>B</u>	<u>CONTENT</u>	<u>PAGE</u>
B.1	ALIGNMENT	1
B.2	PROFILE	1
B.3	EXCAVATION	1
B.4	EXCAVATED MATERIAL	2
B.5	EXCAVATION AT EXISTING BRIDGE AND CULVERT SITES	2
B.6	PIPE CULVERTS	2
B.7	RIP-RAP PROTECTION FOR CULVERTS	3
B.8	CLEARING, GRUBBING AND MULCHING	3
B.9	TRIBUTARY TILE OUTLETS	3
B.10	SEEDING	3
B.11	COMPLETION	4



# DIVISION B

## SPECIFICATIONS FOR OPEN DRAINS

---

### B.1 ALIGNMENT

The drain shall be constructed in a straight line and shall follow the course of the present drain or water run unless noted on the drawings. Where there are unnecessary bends or irregularities on the existing course of the drain, the Contractor shall contact the Engineer before commencing work to verify the manner in which such irregularities or bends may be removed from the drain. All curves shall be made with a minimum radius of fifteen (15) metres from the centre line of the drain.

### B.2 PROFILE

The Profile Drawing shows the depth of cuts from the top of the bank to the final invert of the ditch in metres and decimals of a metre, and also the approximate depth of excavated material from the bottom of the existing ditch to the final invert of the ditch. These cuts are established for the convenience of the Contractor; however, bench marks (established along the course of the drain) will govern the final elevation of the drain. The location and elevation of the bench marks are given on the Profile Drawing. Accurate grade control must be maintained by the Contractor during ditch excavation.

### B.3 EXCAVATION

The bottom width and the side slopes of the ditch shall be those shown on the drawings. If the channel cross-section is not specified it shall be a one metre bottom width with 1.5(h):1(v) side slopes. At locations along the drain where the cross section dimensions change, there shall be a transitional length of not less than 10:1 (five metre length to 0.5 metre width differential). Where the width of the bottom of the existing ditch is sufficient to construct the design width, then construction shall proceed without disturbing the existing banks.

Where existing side slopes become unstable, the Contractor shall immediately notify the Engineer. Alternative methods of construction and/or methods of protection will then be determined prior to continuing work.

Where an existing drain is being relocated or where a new drain is being constructed, the Contractor shall strip the topsoil for the full width of the drain, including the location of the spoil pile. Upon completion of levelling, the topsoil shall be spread to an even depth across the full width of the spoil.

An approved hydraulic excavator shall be used to carry out the excavation of the open ditch unless otherwise directed by the Engineer.

#### **B.4 EXCAVATED MATERIAL**

Excavated material shall be placed on the low side of the drain or opposite trees and fences. The Contractor shall contact all Landowners before proceeding with the work to verify the location to place and level the excavated material.

No excavated material shall be placed in tributary drains, depressions, or low areas which direct water behind the spoil bank. The excavated material shall be placed and levelled to a maximum depth of 200 mm, unless instructed otherwise and commence a minimum of one (1) metre from the top of the bank. The edge of the spoil bank away from the ditch shall be feathered down to the existing ground; the edge of the spoil bank nearest the ditch shall have a maximum slope of 2(h):1(v). The material shall be levelled such that it may be cultivated with ordinary farm equipment without causing undue hardship to the farm machinery and farm personnel. No excavated material shall cover any logs, brush, etc. of any kind.

Any stones or boulders which exceed 300mm in diameter shall be removed and disposed of in a location specified by the Landowner.

Where it is necessary to straighten any unnecessary bends or irregularities in the alignment of the ditch or to relocate any portion or all of an existing ditch, the excavated material from the new cut shall be used for backfilling the original ditch. Regardless of the distance between the new ditch and the old ditch, no extra compensation will be allowed for this work and must be included in the Contractor's lump sum price for the open work.

#### **B.5 EXCAVATION AT EXISITING BRIDGE AND CULVERT SITES**

The Contractor shall excavate the drain to the full specified depth under all bridges and to the full width of the structure. Temporary bridges may be carefully removed and left on the bank of the drain but shall be replaced by the Contractor when the excavation is complete. Permanent bridges must, if at all possible, be left intact. All necessary care and precautions shall be taken to protect the structure. The Contractor shall notify the Landowner if excavation will expose the footings or otherwise compromise the structural integrity of the structure.

The Contractor shall clean through all pipe culverts to the grade and width specified on the profile.

#### **B.6 PIPE CULVERTS**

All pipe culverts shall be installed in accordance with the standard detail drawings. If couplers are required, five corrugation couplers shall be used for up to and including 1200mm diameter pipes and 10 corrugation couplers for greater than 1200mm diameter pipes.

When an existing crossing is being replaced, the Contractor may backfill the new culvert with the existing native material that is free of large rocks and stones. The Contractor is responsible for any damage to a culvert pipe that is a result of rocks or stones in the backfill.

### B.7 RIP-RAP PROTECTION FOR CULVERTS

Quarry stone rip-rap shall be used as end treatment for new culverts and placed on geotextile filter material (Mirafi 160N or approved equal). The rip-rap shall be adequately keyed in along the bottom of the slope, and shall extend to the top of the pipe or as directed on the drawings. The maximum slope for rip-rap shall be 1(h):1(v) or as directed by the Engineer.

The Contractor shall be responsible for any defects or damages that may develop in the rip-rap or the earth behind the rip-rap that the Engineer deems to have been fully or partially caused by faulty workmanship or materials.

### B.8 CLEARING, GRUBBING AND MULCHING

Prior to excavation, all trees, scrub, fallen timber and debris shall be removed from the side slopes of the ditch and for such a distance on the working side so as to eliminate any interference with the construction of the drain or the spreading of the spoil. The side slopes shall be neatly cut and cleared flush with the slope whether or not they are affected directly by the excavation. With the exception of large stumps causing damage to the drain, the side slopes shall not be grubbed. All other cleared areas shall be grubbed and the stumps put into piles for disposal by the Landowner.

All trees or limbs 150mm or larger, that is necessary to remove, shall be cut, trimmed and neatly stacked in the working width for the use or disposal by the Landowner. Brush and limbs less than 150mm in diameter shall be mulched. Clearing, grubbing and mulching shall be carried out as a separate operation from the excavation of the ditch, and shall not be completed simultaneously at the same location.

### B.9 TRIBUTARY TILE OUTLETS

All tile outlets in existing ditches shall be marked by the Landowner prior to excavation. The Contractor shall guard against damaging the outlets of tributary drains. Any tile drain outlets that were marked or noted on the drawings and are subsequently damaged by the Contractor shall be repaired by the Contractor at his expense. The Landowner shall be responsible for repairs to damaged tile outlets that were not marked.

### B.10 SEEDING

The side slopes where disturbed shall be seeded using an approved grass seed mixture. The grass seed shall be applied the same day as the excavation of the open ditch.

Grass seed shall be fresh, clean and new crop seed, meeting the requirements of the MTO and composed of the following varieties mixed in the proportion by weight as follows:

- 55% Creeping Red Fescue
- 40% Perennial Rye Grass
- 5% White Clover

Grass seed shall be applied at the rate of 100 kg/ha.

**B.11 HYDRO SEEDING**

The areas specified in the contract document shall be hydro seeded and mulched upon completion of construction in accordance with O.P.S.S. 572.

**B.12 HAND SEEDING**

Placement of the seed shall be of means of an approved mechanical spreader.

**B.13 COMPLETION**

At the time of completion and final inspection, all work in the Contract shall have the full dimensions and cross-sections specified without any allowance for caving of banks or sediment in the ditch bottom.



# DIVISION C

## SPECIFICATIONS FOR TILE DRAINS

---

<u>C</u>	<u>CONTENT</u>	<u>PAGE</u>
C.1	PIPE MATERIALS	1
C.2	ALIGNMENT	1
C.3	PROFILE	2
C.4	EXCAVATION	2
C.5	INSTALLATION	2
C.6	TRENCH CROSSINGS	3
C.7	OUTLET PROTECTION	4
C.8	CATCH BASINS AND JUNCTION BOXES	4
C.9	TRIBUTARY DRAINS	5
C.10	CLEARING, GRUBBING AND MULCHING	5
C.11	ROADS AND LANEWAY SUB-SURFACE CROSSINGS	6
C.12	FILLING IN EXISTING DITCHES	6
C.13	CONSTRUCTION OF GRASSED WATERWAYS	6
C.14	UNSTABLE SOIL	6
C.15	ROCKS	6
C.16	BROKEN OR DAMAGED TILE	7
C.17	RECOMMENDED PRACTICE FOR CONSTRUCTION OF SUBSURFACE DRAINAGE SYSTEMS	7



# DIVISION C

## SPECIFICATIONS FOR TILE DRAINS

---

### C.1 PIPE MATERIALS

#### C.1.1 Concrete Tile

Concrete drain tile shall conform to the requirements of the most recent A.S.T.M. specification for Heavy-Duty Extra Quality drain tile. All tile with diameters less than 600mm shall have a pipe strength of 1500D. All tile with diameters 600mm or larger shall have a pipe strength of 2000D.

All tile furnished shall be subject to the approval of the Engineer. All rejected tile are to be immediately removed from the site.

#### C.1.2 High Density Polyethylene (HDPE) Pipe

All HDPE pipe shall be dual-wall corrugated drainage pipe with a smooth inner wall. HDPE pipe shall have a minimum stiffness of 320 kPa at 5% deflection.

Unless otherwise noted, all sealed HDPE pipe shall have a water tight gasketed bell and spigot joining system meeting the minimum requirements of CSA B182.8. Perforated HDPE pipe shall have a soil tight joining system, and shall be enveloped in non-woven geotextile filter sock.

### C.2 ALIGNMENT

The Contractor shall contact the Engineer to establish the course of the drain. Where an existing drain is to be removed and replaced by the new drain, or where the new drain is to be installed parallel to an existing drain, the Contractor shall locate the existing drain (including repairing damaged tile caused by locating) at intervals along the course of the drain. The costs of locating shall be included in the tender price.

The drain shall run in as straight a line as possible throughout its length, except that at intersections of other watercourses or at sharp corners, it shall run on a curve of at least 15 metres radius. The new tile drain shall be constructed at an offset from and parallel with any ditch or defined watercourse in order that fresh backfill in the trench will not be eroded by the flow of surface water.

The Contractor shall exercise care not to disturb any existing tile drain or drains which parallel the course of the new drain, particularly where the new and existing tile act together to provide the necessary capacity. Where any such existing drain is disturbed or damaged, the Contractor shall perform the necessary repair at his expense.

### C.3 PROFILE

Benchmarks have been established along the course of the drain which are to govern the elevations of the drain. The location and elevations of the benchmarks are shown on the drawings. Tile is to be installed to the elevation and grade shown on the profiles. Accurate grade control must be maintained by the Contractor at all times.

When installing a drain towards a fixed point such as a bore pipe, the Contractor shall uncover the pipe and confirm the elevation a sufficient distance away from the pipe in order to allow for any necessary minor grade adjustments to be made.

### C.4 EXCAVATION

#### C.4.1 Wheel machine

Unless otherwise specified, all trenching shall be carried out with a wheel machine approved by the Engineer. The wheel machine shall shape the bottom of the trench to conform to the outside diameter of the pipe. The minimum trench width shall be equal to the outside diameter of the pipe plus 100mm on each side of the pipe, unless otherwise specified. The maximum trench width shall be equal to the outside diameter of the pipe plus 300mm on each side of the pipe, unless otherwise specified.

#### C.4.2 Scalping

Where the depths of cuts in isolated areas along the course of the drain as shown on the profile exceed the capability of the Contractor's wheel machine, he shall lower the surface grade in order that the wheel machine may trench to the correct depth. Topsoil is to be stripped over a sufficient width that no subsoil will be deposited on top of the topsoil. Subsoil will then be removed to the required depth and piled separately. Upon completion, the topsoil will then be replaced to an even depth over the disturbed area. The cost for this work shall be included in his tender price.

#### C.4.3 Excavator

Where the use of an excavator is used in-lieu of a wheel machine, the topsoil shall be stripped and replaced in accordance with Item C.4.2. All tile shall be installed on 19mm clear crushed stone bedding placed to a minimum depth of 150mm which has been shaped to conform to the bottom of the pipe. The Contractor shall include the costs of this work in his tender price.

### C.5 INSTALLATION

#### C.5.1 Concrete Tile

The tile is to be laid with close joints and in regular grade and alignment in accordance with the drawings. The tiles are to be bevelled, if necessary to ensure close joints. The inside of the tile is to be kept clear when laid. The sides of the tile are to be supported by partial filling of the trench

(blinding) prior to inspection by the Engineer. No tile shall be backfilled until inspected by the Engineer unless otherwise permitted by the Engineer. The tile shall be backfilled such that a sufficient mound of backfill is placed over the trench to ensure that no depression remains after settling occurs in the backfill.

Where a tile connects to a catch basin or similar structure, the Contractor shall include in his tender price for the supply and placement of compacted Granular 'A' bedding or 19mm clear crushed stone under areas backfilled from the underside of the pipe to undisturbed soil. Where a tile drain passes through a bore pit, the Contractor shall include in his tender price for the supply and placement of compacted Granular 'A' bedding or 19mm clear crushed stone from the underside of the pipe down to undisturbed soil with the limits of the bore pit.

The Contractor shall supply and wrap all concrete tile joints with Mirafi 160N geotextile filter material as part of this contract. The width of the filter material should be:

- 300mm wide for tile sizes 150mm diameter to 350mm diameter.
- 400mm wide for tile sizes 400mm diameter to 750mm diameter.
- 500mm wide for tile sizes larger than 750mm diameter.

The filter material shall completely cover the tile joint and shall have a minimum overlap of 300mm. The type of filter material shall be.

#### C.5.2 HDPE Pipe

HDPE pipe shall be installed using compacted Granular 'A' bedding or 19mm clear crushed stone bedding from 150mm below the pipe to 300mm above the pipe. All granular material shall be compacted using a suitable mechanical vibratory compactor. Granular bedding and backfill shall be placed in lifts not exceeding 300mm and compacted to at least 95% Standard Proctor Maximum Dry Density (SPMDD).

Where a pipe connects to a catch basin or similar structure, the Contractor shall include in his tender price for the supply and placement of compacted Granular 'A' bedding or 19mm clear crushed stone under areas backfilled from the underside of the pipe to undisturbed soil. Where a pipe passes through a bore pit, the Contractor shall include in his tender price for the supply and placement of compacted Granular 'A' bedding or 19mm clear crushed stone from the underside of the pipe down to undisturbed soil with the limits of the bore pit.

As determined by the Engineer, unsuitable backfill material must be hauled off-site by the Contractor and Granular "B" shall be used as replacement backfill material.

#### C.6 TRENCH CROSSINGS

The Contractor shall not cross the backfilled trench with any construction equipment or vehicles, except by one designated crossing location on each property. The Contractor shall ensure that the bedding and backfill material at this designated crossing location is properly placed and compacted so as to adequately support the equipment and vehicles that may cross the trench.

The Contractor may undertake any other approved work to ensure the integrity of the tile at the crossing location. The Contractor shall ensure that no equipment or vehicles travel along the length of the trench. The Contractor shall be responsible for any damage to the new tile caused by the construction of the drain.

### C.7 OUTLET PROTECTION

A tile drain outlet into a ditch shall be either HDPE pipe or corrugated steel pipe and shall include a hinged grate for rodent protection. The maximum spacing between bars on the rodent grate shall be 40mm. All corrugated steel outlet pipes shall be bevelled at the end to generally conform to the slope of the ditch bank.

Quarry stone rock rip-rap protection and geotextile filter material (Mirafi 160N), shall be installed around the outlet pipe and extended downstream a minimum distance of three metres, unless otherwise specified. The protection shall extend to the top of the backfilled trench and below the pipe to 300 mm under the streambed. The protection shall also extend 600mm into undisturbed soil on either side of the backfilled trench. In some locations, rip-rap may be required on the bank opposite the outlet.

Where the outlet occurs at the upper end of an open ditch, the rip-rap protection will extend all around the end of the ditch and to a point 800mm downstream on either side. Where heavy overflow is likely to occur, sufficient additional rip-rap and filter material shall be placed as directed by the Engineer to prevent the water cutting around the protection.

### C.8 CATCH BASINS AND JUNCTION BOXES

Unless otherwise noted, catch basins shall be in accordance with OPSD 705.010 and 705.030. The catch basin grate shall be a "Birdcage" type substantial steel grate, removable for cleaning and shall be inset into a recess provided around the top of the structure. The grate shall be fastened to the catch basin with bolts into the concrete. Spacing of bars on grates for use on 600mmX600mm structures shall be 65mm centre to centre. Spacing of bars on grates for use on structures larger than 600mmX600mm shall be 90mm.

All catch basins shall be backfilled with compacted Granular 'A' or 19mm clear crushed stone placed to a minimum width of 300mm on all sides. If settling occurs after construction, the Contractor shall supply and place sufficient granular material to maintain the backfill level flush with adjacent ground. The riser sections of the catch basin shall be wrapped with filter cloth.

Quarry stone rip-rap protection shall be placed around all catch basins and shall extend a minimum distance of one (1) metre away from the outer edge of each side of the catch basin, and shall be placed so that the finished surface of the rip-rap is flush with the existing ground.

If there are no existing drains to be connected to the catch basin at the top end of the drain, a plugged tile shall be placed in the upstream wall with the same elevations as the outlet tile.

Junction boxes shall have a minimum cover over the lid of 450mm.

The Contractor shall include in his tender price for the construction of a berm behind all ditch inlet structures. The berm shall be constructed of compacted clay keyed 300mm into undisturbed soil. The top of the spill way of the earth berm shall be the same elevation as the high wall of the ditch inlet catch basin. The earth berm shall be covered with 100mm depth of topsoil and seeded with an approved green seed mixture. The Contractor shall also include for regrading, shaping and seeding of road ditches for a maximum of 15 metres each way from all catch basins.

The Contractor shall clean all catch basin sumps after completion of the drain installation. Catch basin markers shall be placed beside each catch basin.

### C.9 TRIBUTARY DRAINS

Any tributary tile encountered in the course of the drain is to be carefully taken up by the Contractor and placed clear of the excavated earth. If the tributary drains encountered are clean or reasonably clean, they shall be connected into the new drain in accordance with the typical tile drain connection detail. Tributary tile drain connections into the new drain shall be made using high density polyethylene agricultural drain tubing installed on and backfilled with 19mm clear crushed stone. All tile drain connections into the new drain shall be either a cored hole with an insert coupler or a manufactured tee.

Where the existing drains are full of sediment, the decision to connect the tributary drain to the new drain shall be left to the Engineer. The Contractor shall be paid for each tributary drain connection as outlined in the Form of Tender and Agreement.

The Contractor shall be responsible for all tributary tile connections for a period of one year from the date of the Completion Certificate. After construction, any missed tile connections required to be made into the new drain shall be paid at the same rate as defined in the Form of Tender and Agreement. The Contractor will have the option to make any subsequent tile connections or have the Municipality make the required connections and have the cost of which deducted from the holdback.

Where an open ditch is being replaced by a new tile drain, existing tile outlets entering the ditch from the side opposite the new drain shall be extended to the new drain.

Where the Contractor is required to connect an existing tile which is not encountered in the course of the drain, the cost of such work shall constitute an extra to the contract.

### C.10 CLEARING, GRUBBING AND MULCHING

The Contractor shall clear, brush and stump trees from within the working area.

All trees or limbs 150mm or larger, that is necessary to remove, shall be cut, trimmed and neatly stacked in the working width for the use or disposal by the Landowner. Brush and limbs less than 150mm in diameter shall be mulched.

Clearing, grubbing and mulching shall be carried out as a separate operation from installing the drain, and shall not be completed simultaneously at the same location.

### C.11 ROADS AND LANEWAY SUB-SURFACE CROSSINGS

All roads and laneway crossings may be made with an open cut. The Contractor may use original ground as backfill to within 600mm of finished grade only if adequate compaction and if the use of the original ground backfill has been approved beforehand by the Engineer.

### C.12 FILLING IN EXISTING DITCHES

The Contractor shall backfill the ditch sufficiently for traversing by farm equipment. If sufficient material is available on-site to fill in the existing ditch, the topsoil shall be stripped and the subsoil shall be bulldozed into the ditch and the topsoil shall then be spread over the backfilled waterway. The Contractor shall ensure sufficient compaction of the backfill and if required, repair excess settlement up to the end of the warranty period.

### C.13 CONSTRUCTION OF GRASSED WATERWAYS

Where the Contractor is required to construct a grassed waterway, the existing waterway shall be filled in, regraded, shaped and a seed bed prepared prior to applying the grass seed. The grass seed shall be fresh, clean and new crop seed, meeting the requirements of the MTO.

- 55% Creeping Red Fescue
- 15% Perennial Rye Grass
- 27% Kentucky Bluegrass
- 3% White Clover

Grass seed shall be applied at the rate of 100 kg/ha.

### C.14 UNSTABLE SOIL

The Contractor shall immediately contact the Engineer if unstable soil is encountered. The Engineer shall, after consultation with the Contractor, determine the action necessary and a price for additions or deletions shall be agreed upon prior to further drain installation.

### C.15 ROCKS

The Contractor shall immediately contact the Engineer if boulders of sufficient size and number are encountered such that the Contractor cannot continue trenching with a wheel machine. The Engineer shall determine the action necessary and a price for additions or deletions shall be agreed upon prior to further drain installation.

If only scattered large stone or boulders are removed on any project, the Contractor shall either excavate a hole to bury same adjacent to the drain, or he shall haul the stones or boulders to a location designated by the Landowner.



**C.16 BROKEN OR DAMAGED TILE**

The Contractor shall remove and dispose of all broken (existing or new), damaged or excess tile off site.

**C.17 RECOMMENDED PRACTICE FOR CONSTRUCTION OF SUBSURFACE DRAINAGE SYSTEMS**

Drainage Guide for Ontario, Ministry of Agriculture, Food and Rural Affairs, Publication 29 and its amendments, dealing with the construction of Subsurface Drainage Systems, shall be the guide to all methods and materials to be used in the construction of tile drains except where superseded by other Specifications of the Contract.



# **DIVISION E**

## **SPECIFICATIONS FOR DRAINAGE CROSSINGS BY THE BORING METHOD**

---

<u>E</u>	<u>CONTENT</u>	<u>PAGE</u>
E.1	GENERAL REQUIREMENTS	1
E.2	NOTIFICATION	1
E.3	PIPE	1
E.4	INSTALLATION	1
E.5	AUGER PIT	2
E.6	CONSTRUCTION	2
E.7	ACCEPTANCE	2



# **DIVISION E**

## **SPECIFICATIONS FOR DRAINAGE**

### **CROSSINGS BY THE BORING METHOD**

---

#### **E.1 GENERAL REQUIREMENTS**

When a drainage crossing of a Roadway, Railway, etc. is to be carried out by the Boring Method, the following Specifications for this work shall apply. The Authority having jurisdiction over the lands involved with the crossing will supply no labour, equipment or materials for the construction of the crossing unless otherwise specified.

The Contractor shall be fully responsible for availing himself of, and satisfying any further Specifications that may apply to borings affecting the Authority having jurisdiction over the lands involved with the crossing.

#### **E.2 NOTIFICATION**

The Contractor shall give the Authority responsible for the lands being crossed at least five (5) days notice before he commences any work on the crossing.

#### **E.3 PIPE**

The pipe or casing used in the crossing shall be smooth wall welded steel pipe with a minimum wall thickness as specified on the Plan and Profile. All pipe shall be new and manufactured from weldable steel having a minimum yield strength of 241 MPa. Pipe ends shall be bevel edged in the intrude to an angle of thirty (30) degrees for butt weld splicing. The name or trademark of the manufacturer and the heat number shall be clearly marked in the inside of the section of the pipe.

The pipe shall be of sufficient length so that during placement, no part of any excavation shall be closer than three (3) metres to the edge of a pavement and the slope of the excavation from the edge of shoulder, or other point as specified to the invert of the pipe shall be no less than one (1) metre vertical to one (1) metre horizontal (1:1) [See item E.5 "Auger Pit"].

#### **E.4 INSTALLATION**

The pipe or casing shall be placed by means of continuous flight augering inside the casing and simultaneous jacking to advance the casing immediately behind the tip of the auger. Complete augering of a tunnel slightly larger than the pipe and placing the entire length by pulling or jacking after completion of the tunnel will not be acceptable unless the method to be adopted is approved in advance by both the Engineer and the Authority responsible for the lands being crossed.

### E.5 AUGER PIT

The pit excavated to accommodate the boring machine shall be so constructed so that the top edge of the pit shall not be closer than three (3) metres to the edge of the pavement. The slope of the pit from the top edge at the shoulder to the bottom of the pit shall not be steeper than one (1) metre vertical to one (1) metre horizontal (1:1). Shoring, sheeting, etc. shall be in accordance with the applicable and most recent Provincial Statutes.

The pit shall be left open for an absolute minimum of time, and if at all possible work shall be so scheduled so that excavation, placement of pipe and backfilling take place in one (1) working day. If this is not possible, every effort should be made to schedule the work so that the pit is not left open for more than one (1) day before and one (1) day after the boring operation.

### E.6 CONSTRUCTION

During excavation, every effort should be made to place the top 300 mm of spoil (topsoil) in a separate pile for replacement on top on completion of the backfill operation. If this is not possible or practical, the Contractor shall import and place a minimum of 150 mm of good quality topsoil over the excavated and backfilled area. The finished work shall be left in a clean and orderly condition flush or slightly higher than the adjacent ground so that after settlement, it will conform to the surrounding ground. Excess earth (if any) shall be disposed of as directed by the Engineer and no additional payment will be allotted for such work.

The Contractor shall at his expense supply, erect and maintain suitable and adequate barricades, flashing lights, warning signs and/or flagmen to the satisfaction of the Engineer to adequately warn and protect the motoring public.

Any areas disturbed within the Right-of-Way of a County Road or King's Highway during construction, shall be covered with a minimum of 75 mm of topsoil, fertilized and seeded with an approved grass seed mixture.

### E.7 ACCEPTANCE

All work undertaken by the Contractor shall be to the satisfaction of the Engineer.

# DIVISION H

## SPECIAL PROVISIONS

---

<u>H</u>	<u>CONTENT</u>	<u>PAGE</u>
H.1	GENERAL	2
H.2	UTILITIES	2
H.3	WORKING AREA AND ACCESS	2
H.4	TOPSOIL	2
H.5	RIP-RAP	2
H.6	EXISTING DRAINS/TILE CONNECTIONS	3
H.7	PIPE, INSTALLATION, BEDDING & BACKFILL	3
H.8	ROAD CROSSINGS	4





# DIVISION H

## SPECIAL PROVISIONS

---

**Municipal Drain No. 39 - 2018**  
**Town of Minto**

**Reference No. 1617**

Special provisions means special directions containing requirements particular to the work not adequately provided for by the standard or supplemental Specifications. Special provisions shall take precedence and govern any standard or supplemental Specifications.

### H.1 GENERAL

The Contractor shall notify the Landowners, the Township Drainage Superintendent (Mike Mclsaac) and the Engineer forty-eight (48) hours prior to construction, and arrange a pre-construction meeting.

The Contractor shall verify the location of the new drainage system with the Engineer prior to construction.

The Contractor shall check and verify all dimensions and elevations and report any discrepancies to the Engineer prior to proceeding with the work.

All objects or obstructions within the construction working area such as signs, mailboxes, fences, property ornamentals, etc., that interfere with the installation of the drain shall be removed and re-erected in the same location or another location satisfactory to the Landowner. Any damages to such objects by the Contractor shall be repaired, replaced, installed and paid for by the Contractor at the discretion of the Engineer.

The Contractor shall be responsible to arrange all traffic control signals, signs and devices that are required for safe and proper traffic management during the installation of the drainage system. The Contractor shall contact the Town of Minto for specified local procedures, guidelines and timelines. Traffic control shall meet the standards of Book 7 of the Ontario Traffic Manual.

The Contractor shall be responsible for notifying the public of any road closures or detours unless otherwise stated by the Town of Minto.

The Contractor must maintain access to all driveways along the route of the drain as well as maintain access for all emergency vehicles at all times during construction.

The Contractor shall be responsible for all trench settlement.

### H.2 UTILITIES

All utilities shall be located and uncovered in the affected areas by the Contractor prior to construction.

The Contractor shall arrange to have a representative of the utility owner on site during construction if it is a requirement by the utility owner.

### H.3 WORKING AREA AND ACCESS

The working area for construction purposes shall be a width of twenty-five (25) metres for the Main Drain and Branch 'C', except for in the woodlot on the L. Sinclair property (Roll no. 4-167), part of Lot 7, Concession 7, from Main Drain Sta. 0+000 to Sta. 0+048, where the working area shall be a width of twenty (20) metres.

The working area for maintenance purposed shall be a width of ten (10) metres centered on the proposed tile drain.

Access to the working corridor on the L. Sinclair property, part of Lot 7, Concession 7, shall be along a 5 metre wide access route as shown on the attached Plan (Drawing No. 1 of 2).

Access to the working corridor for Main Drain Sta. 0+079 to Sta. 1+078 and Branch 'C' shall be from where the proposed drain crosses 6<sup>th</sup> Line and 1<sup>st</sup> Road North.

For future maintenance purposes, the landowner on whose property the drainage works is to be repaired shall designate access to and from the working area.

### H.4 TOPSOIL

The Contractor shall strip the topsoil for a minimum width of 10 metres along the route of the proposed tile drainage systems (Main Drain and Branch 'C').

In areas of deep cuts or in the event of poor soil conditions the Contractor shall strip topsoil wider than 10 metres to ensure no contamination of topsoil with subsoil.

The Contractor shall strip the topsoil for a maximum depth of 0.3 metres. In the event that topsoil is greater in depth than 0.3 metres, the Contractor shall make every reasonable effort to not mix the topsoil and subsoil during the backfilling of the trench.

The Contractor shall stockpile the topsoil and later spread it over the backfilled trench.

The Contractor shall use a trim dozer to fine grad the topsoil once it has been placed on the backfilled trench.

Under no circumstances will the Contractor attempt to place frozen topsoil over the backfilled trench.

### H.5 RIP-RAP

All stone rip-rap material to be used around catch basins shall be quarry stone 150 mm to 300 mm dia. and placed to a depth of 450 mm. All rip-rap material shall be placed on geo-textile filter material (Mirafi 180N).

Under no circumstances shall the Contractor substitute broken concrete for rip-rap.

## H.6 EXISTING DRAINS/TILE CONNECTIONS

The Contractor shall uncover the existing drain in several locations prior to the commencement of construction.

The Contractor shall make all tributary tile drain connections in accordance with the Typical Tile Connection Detail on Drawing No. 2.

The Contractor shall be responsible for all tile connections for a period of one year after the issuance of the completion certificate. The tile connections required to be made within this warranty period shall be made at the same rate as defined on the Form of Tender and Agreement. After construction, the Contractor will be given the option to make any subsequent tile connections or have the Town of Minto make said connections and have the costs of which deducted from the holdback.

All existing drains cut off during the installation of the new drainage system that will be connected to the new drainage system shall be flagged or marked by the Contractor prior to the connection being made.

## H.7 PIPE, INSTALLATION, BEDDING & BACKFILL

### H.7.1 Concrete Field Tile

All concrete tile shall meet or exceed the strength of 2000D Heavy-Duty Extra Quality Concrete Drain Tile.

Concrete field tile installed by means of an approved hydraulic excavator shall be installed using 19mm (3/4") crushed stone bedding and backfill from 150mm below the pipe to the spring line of the pipe, as per the detail on Drawing No. 2.

Approved native material shall be used as backfill from the spring line to the underside of the topsoil. The backfill shall not be compacted but a sufficient mound shall be left over the trench by the Contractor to allow for settlement flush with adjacent lands. The Contractor shall be responsible for all trench settlement.

The Contractor shall supply and wrap all concrete tile joints with geotextile filter material as part of this contract. The width of the filter material should be 400mm wide.

The filter material shall completely cover the tile joint and shall have a minimum overlap of 300mm. The type of filter material shall be Mirafi 140NC for clay or loam soil conditions and Mirafi 160N for sandy or silty soil conditions.

### H.7.2 High Density Polyethylene Pipe (H.D.P.E.)

An approved hydraulic excavator shall be used for the installation of all H.D.P.E. pipe.

All H.D.P.E. pipe shall be BOSS 2000 (or equivalent) CSA B182.8/320 KPa.

All H.D.P.E. pipe shall be installed using 19mm (3/4") crushed stone bedding from 150mm below the pipe to the spring line of the pipe. Suitable native material shall be used as backfill from the spring line to the underside of the topsoil. The backfill shall not be compacted but a sufficient mound shall be left over the trench by the Contractor to allow for settlement flush with adjacent lands. The Contractor shall be responsible for all trench settlement.

As determined by the Engineer, unsuitable backfill material must be hauled off-site by the Contractor and Granular "B" shall be used as replacement backfill material.

### H.8 ROAD CROSSINGS

The Contractor shall notify the Engineer and local road authority having jurisdiction over the road a minimum of forty-eight (48) hours prior to each of the scheduled crossings through the roads.

All H.D.P.E. pipe installed within the road allowances shall be BOSS 2000 (or equivalent) CSA B182.8-02/320 KPa with bell and spigot water tight joining systems.

The Contractor shall install the new 375 mm diameter H.D.P.E. pipe through 1<sup>st</sup> Road North along the Main Drain by means of an approved hydraulic excavator using the open cut method.

The existing 450 mm diameter C.M.P. surface culvert through 1<sup>st</sup> Road North along the Main Drain shall be removed and disposed of off-site by the Contractor. The Contractor shall install a new 450 mm diameter H.D.P.E. solid pipe surface culvert in place of the existing surface culvert.

The Contractor shall install the 375 mm diameter H.D.P.E. pipe using Granular "A" bedding from 150 mm below the pipe to 300 mm above the new 450 mm diameter H.D.P.E. surface culvert. Granular "B" material shall be used for backfill from 300 mm above the new surface culvert to 200 mm below finished grade. The Contractor shall place 200 mm of Granular "A" material from the top of the Granular "B" to finished grade.

The Contractor shall not use as backfill any existing native material excavated from the crossing unless prior authorization has been obtained from the road authority having jurisdiction over the road. The Contractor shall dispose of all excess excavated material off-site.

All granular materials shall be placed equally and simultaneously on both sides of the pipe in lifts not exceeding 300 mm. All granular materials used as bedding and backfill within the road allowance shall be thoroughly compacted to at least 95% Standard Proctor Density using an approved vibratory compactor.

The Contractor shall be responsible for all trench settlement.

The Main Drain crossings through 6<sup>th</sup> Line from Sta. 0+489 to Sta. 0+509 and Sta. 1+058 to Sta. 1+078 shall be installed by means of the jack and bore method.

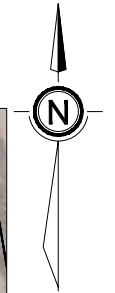

- NOTES:**
1. ALL SOLID HIGH DENSITY POLYETHYLENE PIPE SHALL BE BELL & SPIGOT CSA B182.8 UNLESS OTHERWISE NOTED.
  2. ALL PERFORATED HIGH DENSITY POLYETHYLENE PIPE SHALL BE EXTERNAL SPLIT COUPLER JOINING SYSTEMS UNLESS OTHERWISE NOTED.

- BENCHMARK No. 1** ELEV.=405.23  
NAIL IN NORTH FACE OF HYDRO POLE 150 METRES SOUTH OF STA. 0+000 (MAIN)
- BENCHMARK No. 2** ELEV.=406.38  
TOP CENTRE DOWNSTREAM END OF 450mm DIA. C.M.P. AT STA. 0+058 (BRANCH 1)
- BENCHMARK No. 3** ELEV.=407.86  
TOP CENTRE UPSTREAM END OF 450mm DIA. AG TUBE AT STA. 1+075 (MAIN)

**LEGEND:**

- DRAIN NAME —> EXISTING MUNICIPAL DRAIN
- - - - - INTERIOR/EXTERIOR WATERSHED BOUNDARY
- — — — — PROPERTY BOUNDARY
- — — — — LOT OR CONCESSION BOUNDARY
- — — — — TOWNSHIP BOUNDARY
- EXISTING CATCH BASIN OR JUNCTION BOX
- EXISTING MANHOLE
- DRAIN NAME —> MUNICIPAL DRAIN (AREA OF WORK)
- - - - - WATERSHED BOUNDARY
- PROPOSED CATCH BASIN OR JUNCTION BOX
- PROPOSED MANHOLE
- BENCHMARK LOCATION
- B.M. 1 ELEV.=50.00
- BENCHMARK ELEVATION

No.	ISSUES AND REVISIONS	DATE	BY
3.	REPORT SUBMISSION	2018-06-20	DEL
2.	INFORMATION MEETING	2018-03-09	DEL
1.	ON-SITE MEETING	2016-11-04	DEL



PROJECT: MUNICIPAL DRAIN NO. 39 - 2018

DRAWING: Plan

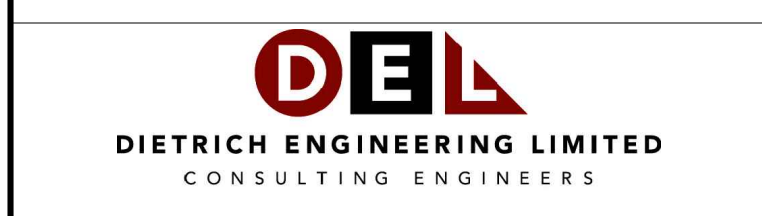

10 Alpine Court, Kitchener, ON, N2E 2M7

PROJ. MGR:	G.N.	DESIGNED BY:	G.C.	DRAWN BY:	G.C.	CHECKED BY:	G.N.
DRAWING SCALE:	AS NOTED	DATE:	JUNE 20, 2018	PROJECT No.:	1617	DRAWING No.:	1 of 2

**PLAN**

PLAN SCALE

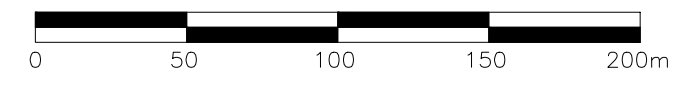

**TILE SIZES**

**MAIN DRAIN**

No.	ITEM	SIZE (mm)	STATION	LENGTH (m)	THICKNESS (mm)	BOTTOM WIDTH
1.	HIGH DENSITY POLYETHYLENE OUTLET PIPE	450	0+000 - 0+006	6		0.9m
2.	HIGH DENSITY POLYETHYLENE PIPE	450	0+006 - 0+079	73		
3.	CONCRETE FIELD TILE	450	0+079 - 0+412	333		
4.	HIGH DENSITY POLYETHYLENE PIPE	450	0+412 - 0+489	77		
5.	SMOOTH WALL STEEL CASING	500 O.D.	0+489 - 0+509	20	9.53	
6.	CONCRETE FIELD TILE	400	0+509 - 0+778	269		1.5:1
7.	HIGH DENSITY POLYETHYLENE PIPE	375	0+778 - 0+798	20		
8.	CONCRETE FIELD TILE	300	0+798 - 1+058	260		
9.	SMOOTH WALL STEEL CASING	400 O.D.	1+058 - 1+078	20	9.53	

**BRANCH 1**

No.	ITEM	SIZE (mm)	STATION	LENGTH (m)	THICKNESS (mm)
1.	CONCRETE FIELD TILE	200	0+000 - 0+058	58	

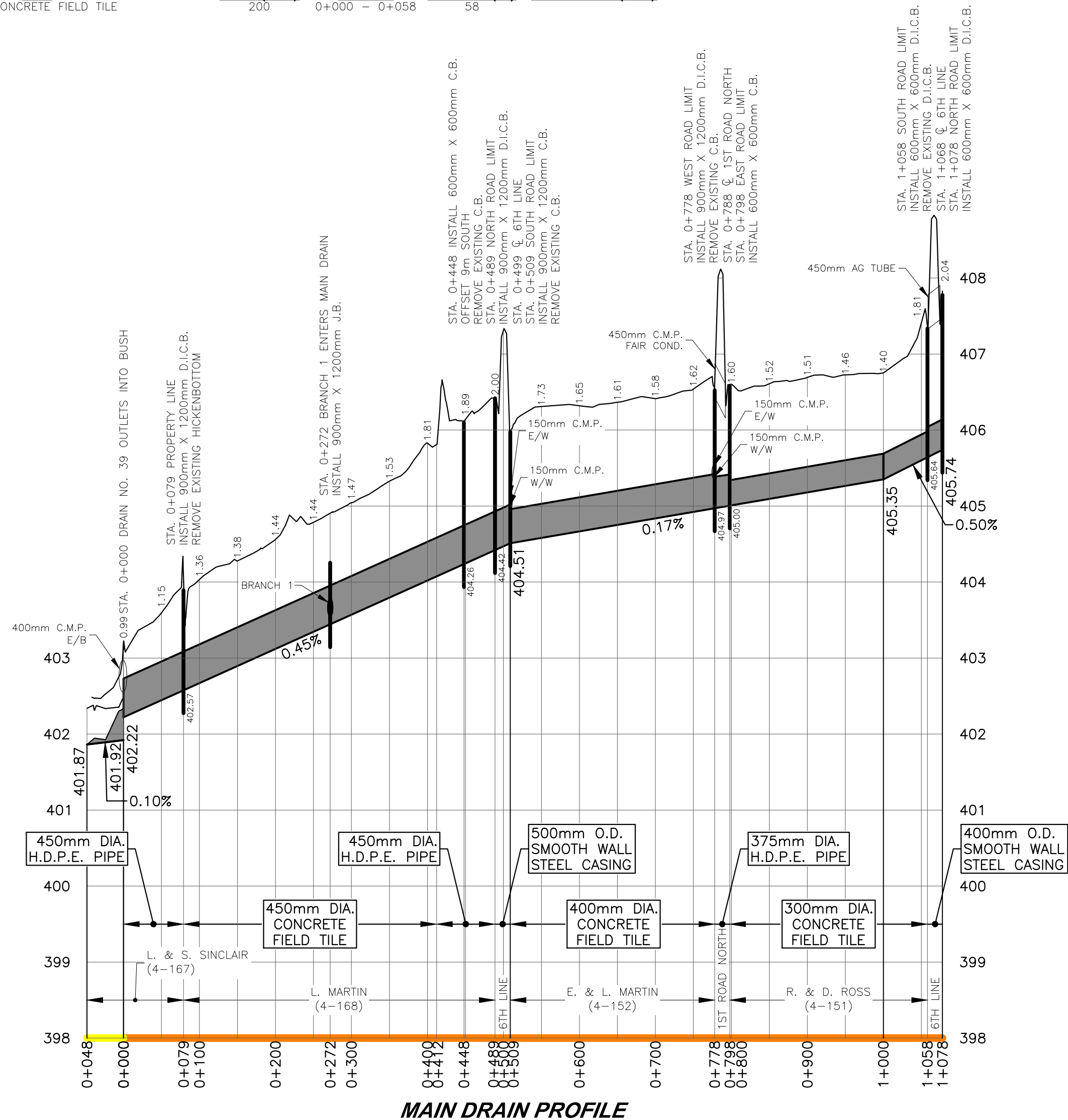

**MAIN DRAIN PROFILE**

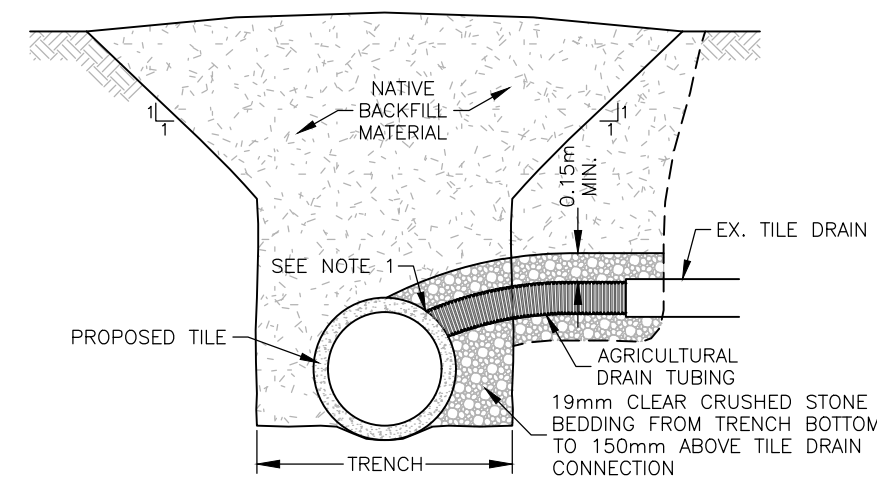
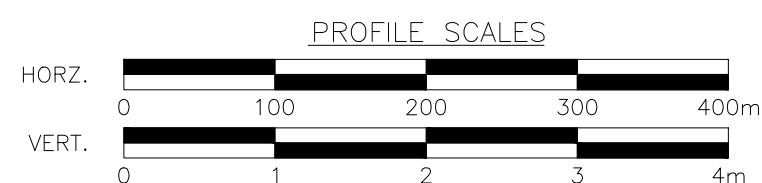

- NOTE:
- ALL TILE CONNECTIONS TO BE EITHER A CORED HOLE WITH AN INSERT COUPLER, OR A MANUFACTURED TEE.
  - CLEAR CRUSHED STONE BEDDING NOT REQUIRED IF DUAL WALL H.D.P.E. PIPE IS USED FOR THE CONNECTION.

**TYPICAL TILE CONNECTION DETAIL**

N.T.S.

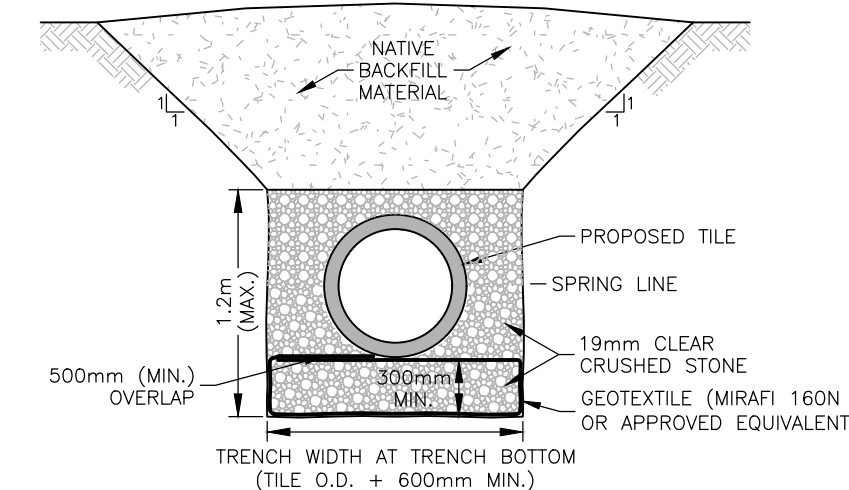

NOTE: FOR DRAIN INSTALLATION BY MEANS OF HYDRAULIC EXCAVATOR

**TYPICAL DRAIN INSTALLATION ON WRAPPED STONE BEDDING DETAIL**

N.T.S.

**NOTES:**

- ALL SOLID HIGH DENSITY POLYETHYLENE PIPE SHALL BE BELL & SPIGOT CSA B182.8 UNLESS OTHERWISE NOTED.
- ALL PERFORATED HIGH DENSITY POLYETHYLENE PIPE SHALL BE EXTERNAL SPLIT COUPLER JOINING SYSTEMS UNLESS OTHERWISE NOTED.

**LEGEND:**

	EXISTING MUNICIPAL DRAIN
	WATERSHED BOUNDARY
	PROPERTY BOUNDARY
	TOWNSHIP BOUNDARY
	EXISTING CATCH BASIN OR JUNCTION BOX
	EXISTING MANHOLE
	MUNICIPAL DRAIN (AREA OF WORK)
	PROPOSED CATCH BASIN OR JUNCTION BOX
	PROPOSED MANHOLE
	BENCHMARK LOCATION
	B.M. 1 ELEV. = 50.00
	BENCHMARK ELEVATION

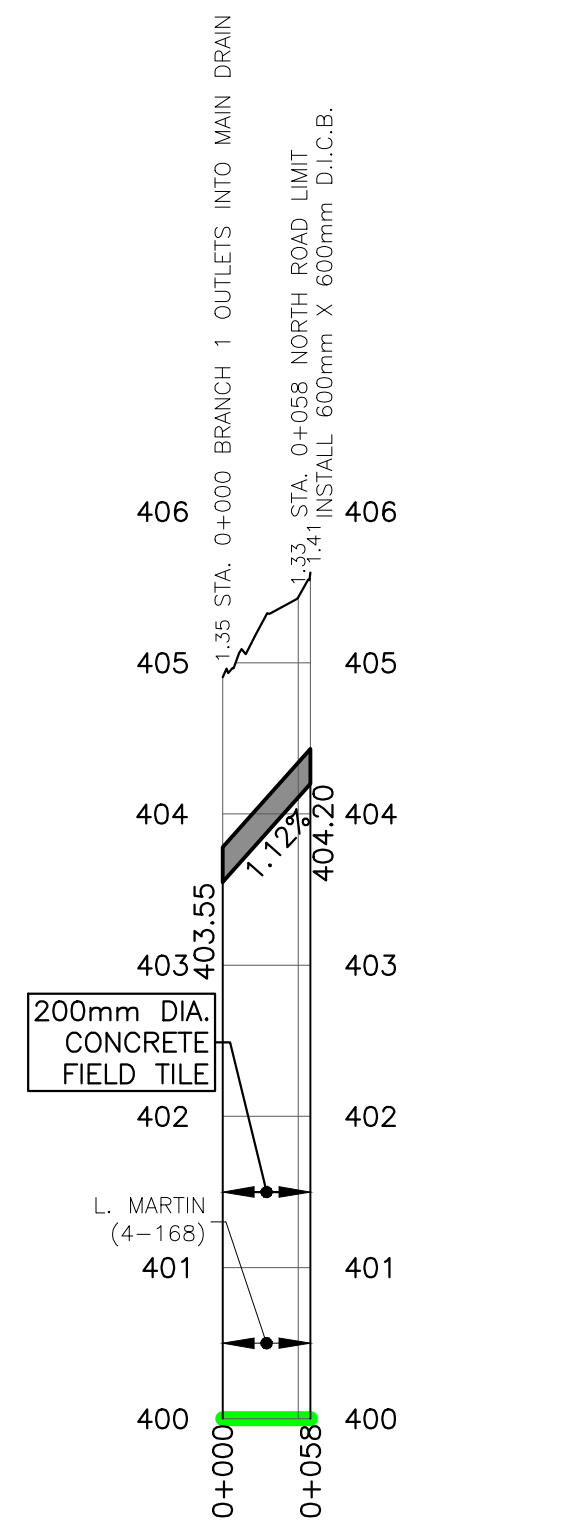

**BRANCH 1 PROFILE**

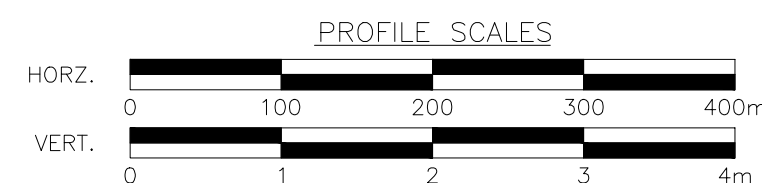

3.	REPORT SUBMISSION	2018-06-20	DEL
2.	INFORMATION MEETING	2018-03-09	DEL
1.	ON-SITE MEETING	2016-11-04	DEL

No.	ISSUES AND REVISIONS	DATE	BY



PROJECT: MUNICIPAL DRAIN NO. 39 - 2018

DRAWING: Profiles

**DEL**

**DIETRICH ENGINEERING LIMITED**  
CONSULTING ENGINEERS

10 Alpine Court, Kitchener, ON, N2E 2M7

PROJ. MGR:	G.N.	DESIGNED BY:	G.C.	DRAWN BY:	G.C.	CHECKED BY:	M.T.
DRAWING SCALE:	AS NOTED	DATE:	JUNE 20, 2018	PROJECT No.	1617	DRAWING No.	2 of 2

Z:\PROJECTS\2016\1617 MUNICIPAL DRAIN NO. 39\DRAWINGS\1617 DRAIN NO.39 - REPORT - JUNE 20